



# HASEGAWA

## GENERAL CATALOGUE Vol.4-2

### GENERAL CATALOGUE Vol.4-2

## HASEGAWA ELECTRIC CO., LTD.

■Head office/Sales division  
5-8-17 Shioe, Amagasaki-city, Hyogo 661-0976  
Tel.+81-6-6423-7015 Fax.+81-6-6429-0016

■Tokyo Branch  
Seavens-N Bldg 20F. 1-2-1 Shibaura,Minato-ku, Tokyo 105-0023  
Tel.+81-3-6722-0193 Fax.+81-3-6722-0194

■Nagoya sales office  
NT Bldg. 2-15-8 Nakata, Chigusa-ku, Nagoya 464-0074  
Tel.+81-52-386-8318 Fax.+81-52-386-8317

■Sendai sales office  
Sendai Hirose Street Bldg 7F. 2-5-1 Honcho, Aoba-ku, Sendai 980-0014  
Tel.+81-22-265-9378 Fax.+81-22-713-6392

■URL : <https://www.hasegawa-elec.co.jp/en>

■E-mail: [info-inquiry@hasegawa-elec.co.jp](mailto:info-inquiry@hasegawa-elec.co.jp)

CATALOGUE-H01-0005-5 '26.3.1000D

Note : Specifications and prices are subject to change for improvement without prior notices.

All rights reserved.

(C)2026 HASEGAWA Electric Co.,Ltd. All rights reserved.



Voltage Detector

Phase Tester

Voltage Detector Checker

Device for Voltage Detection  
& Hot Line Proximity Alarm

Railway Products

Measuring Instrument

Grounding Hook

Disconnecter Hook Stick

Discharge Stick

## HASEGAWA ELECTRIC CO., LTD.

<https://www.hasegawa-elec.co.jp/en>

# A NEW CHALLENGE AS PIONEER

## Rising to New Challenges as a Pioneer

HASEGAWA ground-fault relays, voltage detectors, phase testers, and measuring instruments are essential to protect the safety of human lives and our society.

In this age of electronics, one that continues to progress in complexity, the importance of these products are increasing at an alarming rate.

From extra-high voltage to low-voltage products and AC to DC products used in a variety of scenes from power companies, railway companies, and FA factories for manufacturing companies to various households, our company's products play a key role in creating safe electrical environments.

We contribute to "safe electricity" by providing high-level technical skills and wholehearted devotion. We make full use of our sensing technology to make greater leaps in our development.

Since its founding in 1925, our company has strived to develop and produce products that are key to creating safe electrical environments through products such as ground-fault relays, voltage detectors, and phase testers.

As a result, we have been able to establish ourselves as the top manufacturer in the voltage detector field, and through our original research and technology in both AC and DC relays, we have developed one-of-a-kind products and have received high praise. This is simply a result of our thorough application of "worksites principles", and it is precisely because our entire company takes a position of wholeheartedly responding to the demands of our customers under the motto of "the truth is in the worksite" that we have been able to grow as a total-solutions consulting company for "electrical safety".

Additionally, in recent years we have been grabbing attention in the overseas market and not just in Japan. Notably, in Southeast Asia, the HASEGAWA brand is recognized as proof of safety and reliability. We take pride in being able to contribute to our

customers, which include many infrastructure-related enterprises that support people's lives, such as power, gas, sewer, railroad, and communication companies, and in the future, we would like to make full use of our sensing technology to make great leaps in our development. We at Hasegawa believe that it is our social duty to create "a society free of electrical accidents", and it is our intention to continue this duty with untiring efforts. It is our hope that you will continue to support and guide us in our endeavors from now and into the future.



PRESIDENT

吉田洋一郎  
Yojiro Yoshida

We are in constant pursuit of technological innovation in order to create a society of comfortable and safe electronics.

Society ever marches forward, and globally, changes are occurring at such an intensely rapid rate that even the words "IT" and "digital" are becoming obsolete in the world of electronics. HASEGAWA is able to respond to the changes of these times while continuing to be the top manufacturer of voltage detectors and relay-related products now and into the future.

To achieve this, we are resolved to never feel satisfied with our current knowledge and technology, and we are engaged in research and development with the aim of creating technology for the next generation and beyond.

The first step of creating ideas for the future starts from our "worksites". We begin by accurately understanding product usage and the demands of our customers. Following this, we continue to listen to our customers and implement their opinions through our processes of development and design, production, quality control, and sales...

Through this constant, cyclical workflow, HASEGAWA aims for greater heights and is working to make "a society free of electrical accidents" a reality.



At HASEGAWA, our work never stops. Through a never-ending cycle of activity, we respond to the demands of the next generation.

We walk in step with our customers and provide support through a 24-hour full-support system. We support our customers through reliable consulting.



Development

We develop our products after giving our full attention to the opinions of our customers and thoroughly analyzing what is being demanded by the market and the times.



Client



Design

We work with the ideas of the product being developed and proceed with design that considers a variety of applications. We also take universal design into account and pursue ease of use.

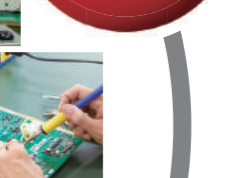

Sales

Not only do we sell products, we also regularly make proposals that can contribute to the work of our customers.



Production

We take the needs of our customers and when products will be used into account to realize a production system that is able to quickly get products on the market.



Quality

We implement strict product testing and checks that reflect the reliability of the HASEGAWA brand to deliver products with confidence.



## Company Overview

**Founded:** July 1925  
**Established:** September 20, 1971  
**Capital:** 41.6 million yen  
 (authorized capital: 64 million yen)  
**Representatives:** Chairman: Osamu Yoshida  
 President: Yojiro Yoshida

### [Locations]

**Head Office:** 5-8-17, Shioe, Amagasaki-city, Hyogo 661-0976  
 TEL: +81-6-6429-6144 FAX: +81-6-6429-0016  
 JR: (071) 3710 FAX: (071) 3710  
**Tokyo Branch:** Seavens-N Bldg 20F. 1-2-1 Shibaura, Minato-ku,  
 Tokyo 105-0023  
 TEL: +81-3-6722-0193 FAX: +81-3-6722-0194  
**Nagoya Sales Office:** NT Bldg. 2-15-8 Nakata, Chigusa-ku, Nagoya  
 464-0074  
 Tel: +81-52-386-8318 Fax: +81-52-386-8317  
**Sendai Sales Office:** Sendai Hirose Street Bldg 7F. 2-5-1 Honcho,  
 Aoba-ku, Sendai 980-0014  
 Tel: +81-22-265-9378 Fax: +81-22-713-6392  
**General Testing Office:** 5-6-20, Shioe, Amagasaki-city, Hyogo 661-0976

### [Business Contents]

**Voltage detectors:** Low voltage detectors, high voltage detectors,  
 extra-high voltage detectors, DC voltage detectors,  
 and other auxiliary devices for voltage detection  
**Phase testers:** Low voltage phase testers, high voltage phase testers,  
 extra-high voltage phase testers  
**Relays:** Bus relays, ground-fault directional relays, ground-fault  
 overvoltage relays, high voltage ground-fault relays,  
 short-circuit relays, DC ground-fault relays, etc.  
**Current transformers:** Zero-phase current transformers  
**Grounding transformers:** Low voltage grounding transformers, high voltage  
 grounding transformers  
**Measuring instrument-related:** Leakage monitors,  $\omega$ C measuring instruments, etc.  
**Grounding tools:** Grounding hook sticks, discharge sticks  
**LED-related:** Working lights, helmet lights, etc.  
**Other:** Consulting related to ground-fault relay systems,  
 measuring systems, etc.  
 Research, design, and production for co-development  
 with customers

### [Major Clients]

Various power companies and related enterprises, various electrical safety  
 associations, various electric construction firms, various companies related  
 to Japan Railways and private railways, NTT, electronic material trading  
 firms, etc.

### [Banks]

MUFG Bank, Amagasaki Ekimae Branch  
 Resona Bank, Dojima Branch  
 Sumitomo Mitsui Bank, Umeda Branch



## We work with our group company to aid in providing stable electrical power.

We work with our group company to contribute to the stability and  
 safety of electrical power supply with a focus on relays, voltage  
 detectors, and other devices that are essential for the protection and  
 maintenance of devices related to electrical power and industrial  
 equipment as well as solar power generation.

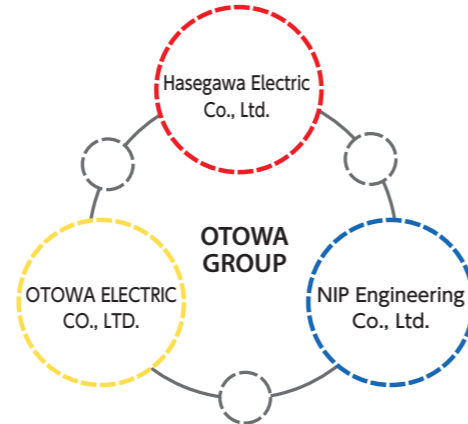

### OTOWA ELECTRIC CO., LTD.

Provides total solutions for lightning-related products, including lightning-resistant  
 elements, the first SPDs for direct lightning hits in Japan, SPDs for power sources, and  
 lightning-resistant transformers.

### NIP Engineering Co., Ltd.

Provides total solutions for anti-lightning measures, including the manufacture, sales,  
 design, construction, and lightning-damage solutions consultation for lightning arrester  
 equipment (lightning rods), as well as the maintenance of solar power generation  
 systems

### Ceraon Co., Ltd.

Manufactures and sells ceramic devices

### Meneon Co., Ltd.

Performs electrical work as well as maintenance and management for electrical  
 facilities

### Geological Assessment Tech Co., Ltd.

Geological survey and water quality survey, grounding design, grounding resistance  
 reduction work and consulting, planning, design, and consultation of external and  
 internal lightning protection measures

### Otowa Korea Co., Ltd.

Sells various lightning arrestors as well as other electronic machinery and devices.

## Our Company's Journey

### [Company History]

- 1925 Founded in Osaka as the Hasegawa Toshihiko Trading Company  
Imports and sells relays, fuses, and voltage detectors
- 1942 Moves to Higashi Yodogawa, Osaka. Begins development and  
manufacture of bus relays and other ground-fault protection  
relays as well as voltage detectors
- 1949 Reorganizes as Hasegawa Electric Co., Ltd. (Hasegawa Denki)
- 1971 Changes trade name to Hasegawa Electric Co., Ltd. (Hasegawa  
Denki Kogyo) Kametaro Yoshida becomes President and  
Representative Director
- 1975 Begins sale of the "HS-7 audible, light-emitting voltage detector"
- 1986 Osamu Yoshida becomes President and Representative Director
- 1995 Issues "The Great Hanshin Earthquake for Our Company"
- 1996 Begins sale of the "HT-610a low voltage detector"
- 1997 Begins sale of the "RRG-1  $\omega$ C measurement type ground fault  
protection relay"
- 1999 The HT-600 series of low voltage detectors achieves 1 million  
units in sales
- 2001 Receives ISO 9001 certification
- 2003 Receives ISO 14001 certification
- 2008 Main factory moves to Shioe, Amagasaki City
- 2011 Issues the technical periodical "Understanding  $\omega$ C Ry"
- 2013 Establishes Sendai Sales Office
- 2014 Tatsuo Matsuoka becomes President and Representative Director
- 2015 First appearance at the Korea Expo (actively participates in  
international exhibitions after this)
- 2017 Head office and factory moves to new building
- 2018 Yojiro Yoshida becomes President and Representative Director

### [Awards Received]

- 1981 "HS Series" wins award at the Japan Electrical Construction and Materials Fair
- 1983 "HP Series" wins award at the Japan Electrical Construction and Materials Fair
- 1986 "HT-600 voltage detector" selected for the Good Design Award G Mark
- 1988 "HSS-6 voltage detector" wins award at the Japan Electrical Construction and  
Materials Fair
- 1989 "HT-610 voltage detector" selected for the Good Design Award G Mark
- 1990 "HPI-A6 phase tester" wins award at the Japan Electrical Construction and Materials Fair
- 1993 "HX-6 hot line proximity alarm" wins award at the Japan Electrical  
Construction and Materials Fair
- 1993 "HST Series voltage detector" selected for the Good Design Award G Mark
- 1994 "VG-UI2T instant ground-fault directional relay" wins award at the Japan  
Electrical Construction and Materials Fair
- 1995 "Research and development of wireless voltage detectors and phase testers"  
wins the Shibusawa Award
- 1996 "Development of  $\omega$ C measurement type ground fault protection relay  
equipment" wins Ohm Technology Award
- 1996 "HT-610a voltage detector" wins Good Design Award Commissioner's Special  
Prize for Products of Small and Medium Enterprises
- 1999 "Development of lead-less voltage detectors" wins the Shibusawa Award
- 1999 "RRG-1B relay" wins award at the Japan Electrical Construction and Materials Fair
- 2000 "Lead-less phase tester" wins award at the Japan Electrical Construction and Materials Fair
- 2001 "Development of extendable voltage detectors" wins the Shibusawa Award
- 2003 "HSE-7T voltage detector for high voltage" wins award at the Japan Electrical  
Construction and Materials Fair
- 2005 "RRG-3  $\omega$ C measurement type ground fault protection relay" wins the  
Shibusawa Award
- 2007 Selected as one of the Small and Medium Enterprise Agency's "300 Small  
and Medium Enterprises Engaged in Spirited Manufacturing"
- 2007 "HT-610a voltage detector" wins Good Design/Long Life Design Award
- 2010 Recognized as a leading technology enterprise in the Southern Hanshin area
- 2013 "Development of contactless AC voltage detectors" wins Railway Electrical  
Engineering Award
- 2013 "HXR contactless AC voltage detector" wins award at the Japan Electrical  
Construction and Materials Fair
- 2014 Presented with a "Certificate of Excellence in Declaration as a Corporation" by  
the Amagasaki Tax Office



Shibusawa Awards



Various awards from the Japan Electrical Construction Association



The Small and Medium Enterprise Agency's 300 Small and Medium Enterprises Engaged in Spirited Manufacturing



Ohm Technology Award

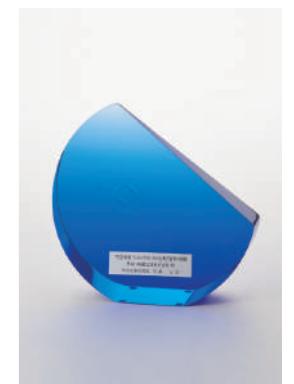

Good Design Commissioner's Special Prize for Products of Small and Medium Enterprises

# High voltage

# Low voltage

Voltage detector P.24 to 29  
 Phase tester P.31 to 32  
 Portable live part detector P.35  
 Grounding hook P.50 to 57  
 Disconnecter hook stick P.58

For electric substation equipment

Extra-High Voltage Detecting System (VOLTECT) P.47 to 48

Hydroelectric power plant

Wind force power generation system

high voltage substation

154kV~187kV

Primary substation

275kV~500kV

Nuclear power plant

Thermal electric power plant

For photovoltaic power generation system (DC)

Voltage detector P.19 to 20, 23

Voltage detector P.17 to 20  
 Phase tester P.30

# Medium voltage

66kV~77kV

Substation for electric power distribution

6.6kV~36kV

Electricity distribution lines

6.6kV~36kV

6.6kV~36kV

Factories

Buildings

100~440V

Shopping street

Residences

Voltage detector P.21 to 29, 35  
 Phase tester P.31 to 32  
 Portable live part alarm P.35  
 Hot line proximity alarm P.37 to 39

Grounding hook P.50 to 57  
 Disconnecter hook stick P.58  
 Discharge stick P.59 to 60

For railways (conventional railroad lines, bullet train, monorail)

Voltage detector P.41 to 45  
 Grounding hook P.46

Medium voltage hot line proximity alarm P.45

For receiving plant equipment

Extra-High Voltage Detecting System (VOLTECT) P.47 to 48

Common

Voltage detector checker P.34 to 35



# APPLICATIONS

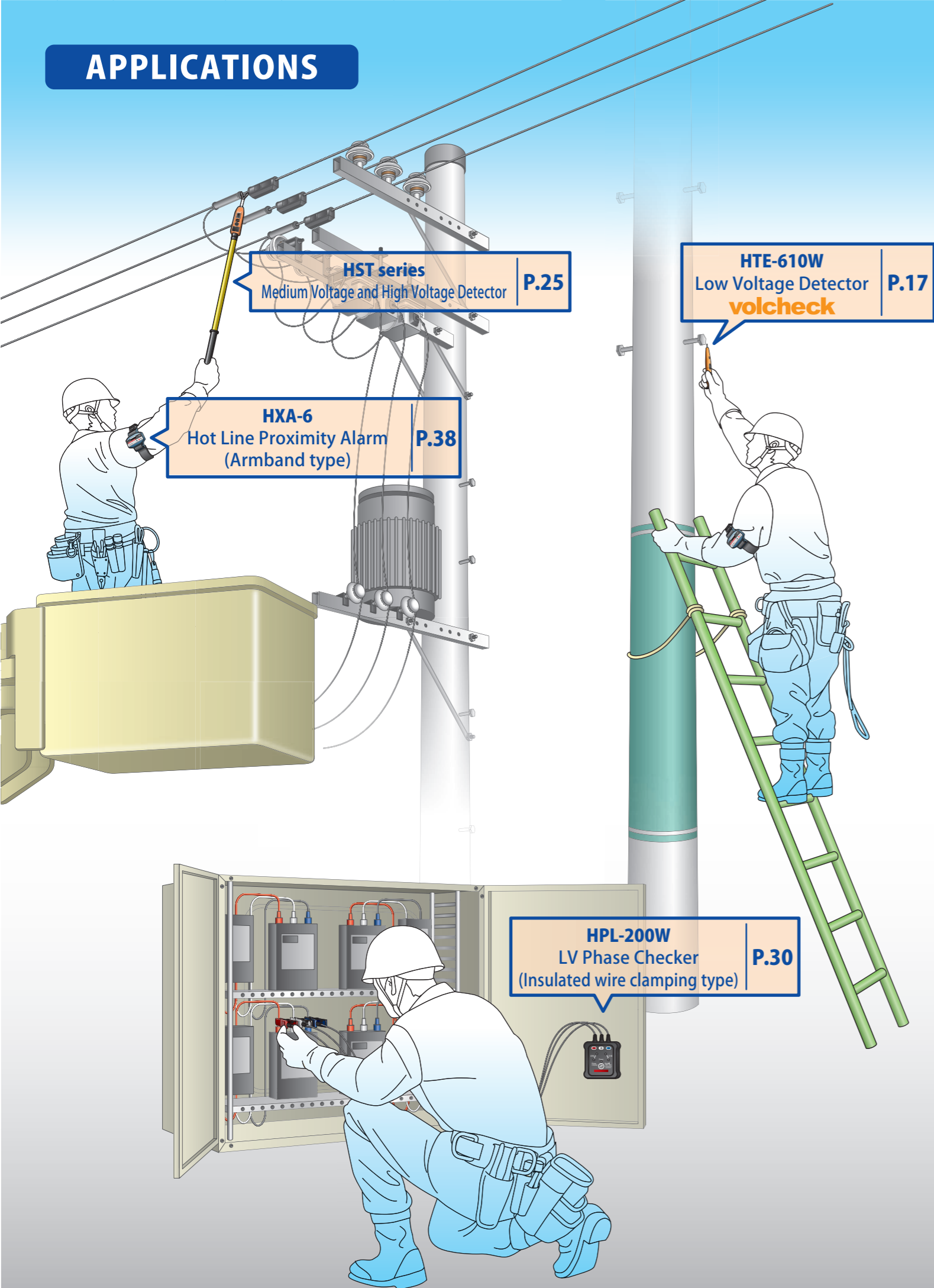

# APPLICATIONS

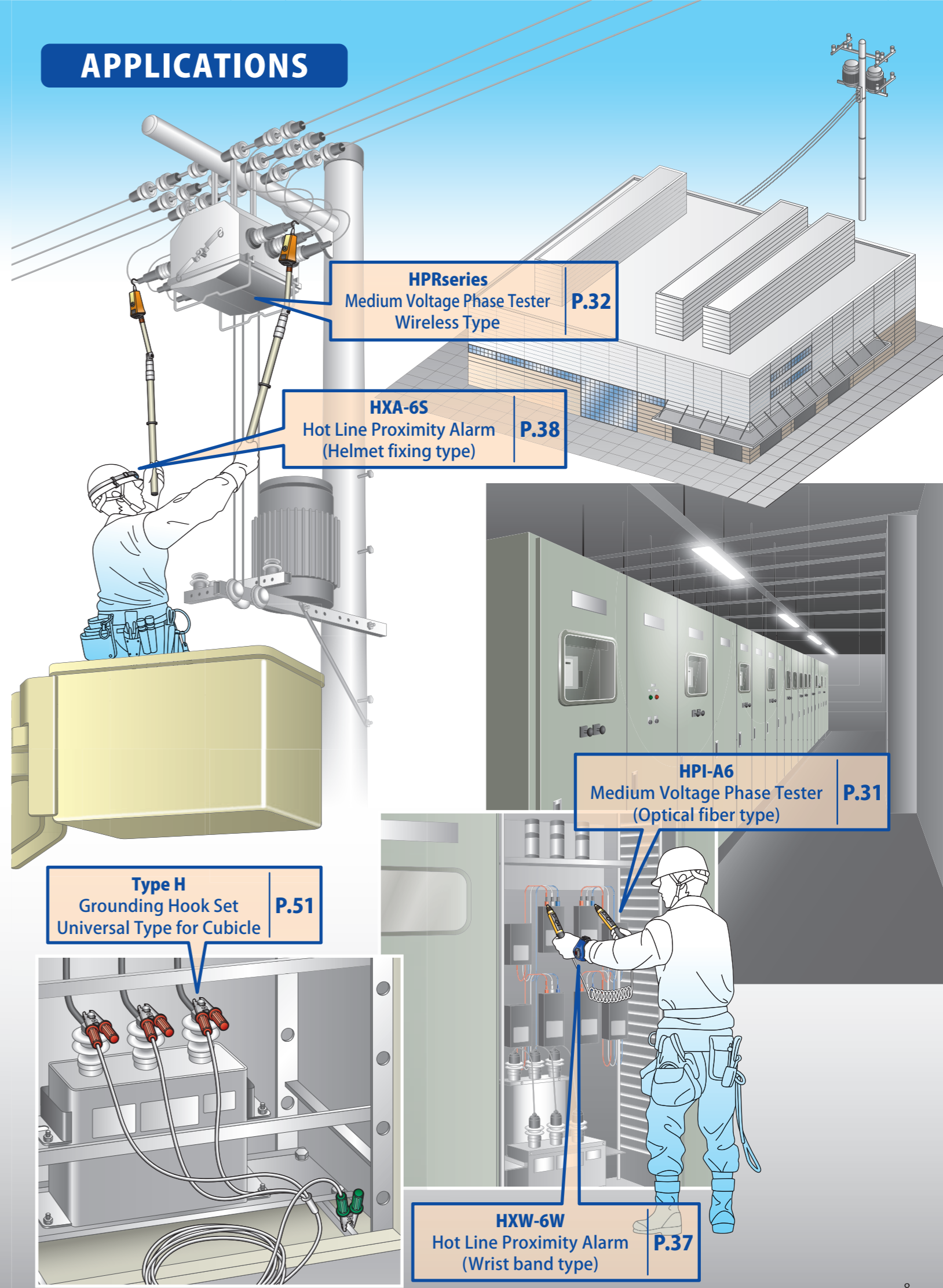

# APPLICATIONS

DC railway

**HSN-6A2**  
Voltage Detector for LV and MV | **P.23**

**HVC-1.5N3**(For railways)  
Voltage Detector for DC Railway | **P.41**

**Grounding Hook**  
for Railway | **P.46**

# APPLICATIONS

AC railway

**HST-L series**  
Voltage Detector for MV and HV | **P.26**

**HXR-25J**(For Shinkansen)  
Medium Voltage Hot-line Proximity Alarm | **P.45**

**HST-W80JS**  
Voltage Detector for AC Railway | **P.45**

## ① HTE-610W Low Voltage Detector Standard Model

② Low Voltage Detector  
**volcheck**

③ AC 50V~1kV



### ■Features

- Highly convenient
  - Voltage detection through covering (sheath)
  - Sensitivity adjustment
- Designed with user safety and security in mind
  - Conductive rubber provides a high level of safety
  - CAT III 1000V

### ■Dimensions: HTE-610W

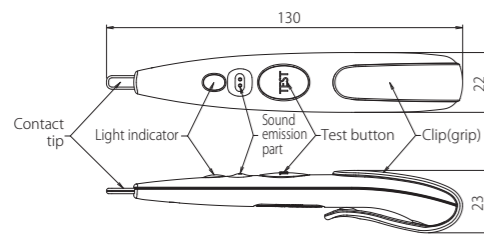

### ■Specifications

|  |   |
|--|---|
| Model  | HTE-610W  |
| Working voltage range                          | AC50V~1kV 50/60Hz   |
| Insulation resistance                          | Between contact tip and clip(grip): 100MΩ minimum with a 500V megger  |
| Dielectric strength                            | Ditto:2kV-1 minute  |
| Leakage current                                | Ditto:100 μA maximum  |
| Impulse withstand                              | Ditto:8000V-10 cycles of positive / negative (IEC61010-1 CAT III 1000V equivalent)  |
| Operation starting voltage (Voltage to ground) | Maximum sensitivity: AC40V maximum<br>Minimum sensitivity: Not operation at AC100V<br>Operation at AC200V<br>Ex-Factory: AC40V±10V<br>(when the contact tip is in contact with an internal standard insulated cable (600V-IV2mm <sup>2</sup> )) |
| Operation status display                       | Light: Intermittent red light visible in 8000lx ambient<br>Sound: Intermittent sound of 50dB minimum in 30cm distance   |
| Operating temperature range                    | 0°C ~ +40°C   |
| Weight   | 22g(including batteries)  |
| Battery  | 2 alkaline button cells LR44(1.5V)  |
| Battery life                                   | New battery : In continuous operation 10 hours<br>: In storage 1.5 years  |

### ① Product type    ② Product name    ③ Working voltage range

#### ④ Marking

|   |   |   |  |
|---|---|---|--|
| <b>Audio signaling and light emitting</b><br>Action is notified by sound and light.                               | <b>AC DC</b><br>The product is usable for both AC and DC.   | <b>Telescopic type</b><br>The operating rod is telescopic.  | <b>CE</b><br>This marking is for products for the EU market, conforming relevant standard. |
| <b>Contact tip - Conductive rubber</b><br>Conductive rubber tip prevents accident of short circuit                | <b>Voltage detection over insulation</b><br>Voltage can be detected over the insulation sheath. (Not possible for shielded cables.) | <b>Waterproof equivalent to IPX4 and so on</b><br>Protection against splashes   | <b>RoHS</b><br>The marking is to confirm satisfaction of the RoHS regulation.              |
| <b>Contact tip - made of Conductive resin</b><br>Short circuit prevention. Conductivity is easy to be maintained. | <b>Voltage detection over the insulation *AC only</b><br>Voltage detection over the insulation not possible for DC                  | <b>Waterproof</b><br>Water-resistant structure for rain and water drops   | <b>IEC</b><br>In Conformity to IEC   |
| <b>Contact tip - Replaceable</b><br>Detector tips are sold  | <b>only for bare wire</b><br>Can be used for bare conductor only. Can not be used for insulated conductor.                          | <b>Battery-less</b><br>No battery is used for operation.  |  |
| <b>Sensitivity adjustment</b><br>Sensitivity can be adjusted by turning the volume knob.                          | <b>LED lighting</b><br>LED lamp is equipped to light the target location of voltage detection.                                      | <b>Auxiliary device for voltage detection</b><br>The product is not a voltage detector, but is used to assist voltage detection work. |  |

⑤ **Battery life -----The battery supplied with product is for testing, this battery life shall not be applied.**

# General Catalog of Voltage Detectors

# INDEX

|  |       |
|--|-------|
| How to read this catalog                                       | 11    |
| INDEX  | 12    |
| Voltage Detectors as per working voltages                      | 14    |
| Section Table for Detectors                                    | 15~16 |
|  |       |
| Voltage Detector   | 17~29 |
|  |       |
| Phase Tester   | 30~32 |
|  |       |
| Voltage Detector Checker                                       | 33~34 |
|  |       |
| Device for Voltage Detection & Hot Line Proximity Alarm        | 35~39 |
|  |       |
| Railway Products (except for voltage detector, grounding hook) | 41~46 |
|  |       |
| Measuring Instrument   | 47~48 |
|  |       |
| Grounding Hook   | 51~57 |
|  |       |
| Disconnecter Hook Stick  | 58    |
|  |       |
| Discharge Stick  | 59~60 |
|  |       |
| In order to use the voltage detector correctly                 | 63~66 |
| Confirming dead-line work                                      | 67~68 |
| Product warranty, maintenance                                  | 69~70 |

# Voltage Detector

- Voltage Detector ..... P.17
- Phase Tester ..... P.30
- Voltage Detector Checker ..... P.33
- Device for Voltage Detection & Hot Line Proximity Alarm ..... P.35

## Voltage Detectors as per working voltages

### ■ For Low Voltage to Medium Voltage

| Model       | Feature  | Voltage     |            |              |     |                        |      |  | Listed page |
|-------------|--|-------------|------------|--------------|-----|------------------------|------|--|-------------|
|             |  | 0V/50V/100V | 600V       | 1kV          | 7kV | 11.4kV                 | 20kV | 25kV                                     |             |
| HTE-610W    |  |             | AC50V~1kV  |              |     |                        |      |  | 17          |
| HTE-610WL   | With LED lighting  |             | AC50V~1kV  |              |     |                        |      |  | 17          |
| HTE-700D/DL |  |             | AC50V~600V |              |     |                        |      |  | 19          |
|             |  |             | DC12V~750V |              |     |                        |      |  |             |
| HT-670      | Voltage discrimination function of 100 V-200 V (* When option is used) |             | AC50V~600V |              |     |                        |      |  | 19          |
|             |  |             | DC50V~600V |              |     |                        |      |  |             |
| HSF-11      |  |             |            | AC80V~11.4kV |     |                        |      |  | 21          |
| HSE-7G      |  |             |            | AC60V~7kV    |     |                        |      |  | 21          |
| HSS-25B1    | Telescopic type  |             |            | AC80V~25kV   |     |                        |      |  | 22          |
| HSS-36B1    | Telescopic type  |             |            | AC80V~36kV   |     |                        |      |  | 22          |
| HSN-6A2     | Telescopic type  |             |            | AC80V~7kV    |     | ~AC10.5kV <sup>①</sup> |      | * Applied only at withstand voltage test | 23          |
|             |  |             |            | DC50V~7kV    |     | ~DC21kV <sup>②</sup>   |      |  |             |
| HST-1.5N    |  |             |            | AC600V~7kV   |     |                        |      |  | 23          |
|             |  |             |            | DC600V~7kV   |     |                        |      |  |             |

### ■ For Medium Voltage to High Voltage

| Model      | Feature                         | Voltage |              |               |              |               |               |       | Listed page |
|------------|---------------------------------|---------|--------------|---------------|--------------|---------------|---------------|-------|-------------|
|            |                                 | 3kV     | 6kV          | 22kV          | 66kV         | 154kV         | 275kV         | 500kV |             |
| HST-20N    |                                 |         | AC3kV~25kV   |               |              |               |               |       | 24          |
|            |                                 |         | DC3kV~25kV   |               |              |               |               |       |             |
| HST-30W    | Telescopic type                 |         | AC3kV~42kV   |               |              |               |               |       | 25          |
| HST-30L    | Telescopic type                 |         | AC3kV~34.5kV |               |              |               |               |       | 26          |
| HST-70L    | Telescopic type                 |         |              | AC20kV~80.5kV |              |               |               |       | 26          |
| HST-W80L   | Telescopic type                 |         |              | AC20kV~80.5kV |              |               |               |       | 26          |
| HSR-500    | Telescopic type                 |         |              |               |              |               | AC250kV~550kV |       | 27          |
| HSR-90N    |                                 |         | AC6kV~90kV   |               |              |               |               |       | 27          |
|            |                                 |         | DC6kV~90kV   |               |              |               |               |       |             |
| HWB-35     | Non-contact type                |         | AC6kV~35kV   |               |              |               |               |       | 28          |
| HWB-138    | Non-contact type                |         |              |               | AC66kV~138kV |               |               |       | 28          |
| HWB-550    | Non-contact type                |         |              |               |              | AC210kV~550kV |               |       | 28          |
| WM-22      | Pinwheel type / Telescopic type |         | AC6kV~22kV   |               |              |               |               |       | 28          |
| WM-33      | Pinwheel type / Telescopic type |         | AC6kV~33kV   |               |              |               |               |       | 28          |
| WM-77A/B/C | Pinwheel type / Telescopic type |         |              | AC11kV~77kV   |              |               |               |       | 28          |
| WM-154A/B  | Pinwheel type / Telescopic type |         |              | AC11kV~154kV  |              |               |               |       | 28          |
| WM-275     | Pinwheel type / Telescopic type |         |              |               | AC33kV~275kV |               |               |       | 28          |
| HWA-33X    | IEC61243-1                      |         | AC11kV~33kV  |               |              |               |               |       | 29          |
| HWA-33P    | Universal joint type            |         | AC1kV~35kV   |               |              |               |               |       | 29          |

### ■ For Railway (for trolley wire)

| Model      | Feature   | Voltage |      |            |                                      |      | Listed page |
|------------|---|---------|------|------------|--------------------------------------|------|-------------|
|            |   | 0V      | 300V | 600V       | 7kV                                  | 20kV |             |
| HVC-1.5N3  | Digital display Function for checking earth wire disconnection      |         |      | DC750~2kV  | * Measurement range is 0V to 1.999kV |      | 41          |
| HVC-750N3  | Digital display Function for checking earth wire disconnection      |         |      | DC300V~2kV | * Measurement range is 0V to 999 V   |      | 42          |
| HVC-1.5N3S | Digital display Function for checking earth wire disconnection      |         |      | DC750~2kV  | * Measurement range is 0V to 1.999kV |      | 43          |
| HVC-1.5N3M | Digital display Function for checking earth wire disconnection      |         |      | DC300V~2kV | * Measurement range is 0V to 1.999kV |      | 43          |
| HSR-1.5NJ  |   |         |      | DC600V~7kV | AC6.6kV                              |      | 44          |
| HSR-1.5NR  | Residual electric charge checking function Standby display function |         |      | DC1kV~7kV  | AC6.6kV                              |      | 44          |

| Model     | Feature                                   | Voltage |     |               |      |       |       |       | Listed page |
|-----------|---|---------|-----|---------------|------|-------|-------|-------|-------------|
|           |   | 3kV     | 6kV | 22kV          | 66kV | 154kV | 275kV | 500kV |             |
| HST-W80JS | Telescopic type/ Standby display function |         |     | AC20kV~80.5kV |      |       |       |       | 45          |

# Section Table for Detectors

## For Low Voltage

| Model                                       | For AC Low Voltage Detector                            | For AC Low Voltage Detector                      | For AC & DC Low Voltage Detector  | For AC & DC Low Voltage Detector                    | For AC & DC Low Voltage Detector                        |
|---|--|--|---|---|---|
|   | HTE-610W   | HTE-610WL  | HTE-700D  | HTE-700DL   | HT-670  |
| Working voltage range                       | AC50V~1kV  | AC50V~1kV  | AC50V~600V<br>DC12V~750V<br>*bare wire only (AC/DC)                     | AC50V~600V<br>DC12V~750V<br>*bare wire only (AC/DC) | AC50V~600V<br>DC50V~600V                                |
| AC  | ●  | ●  | ●   | ●   | ●   |
| DC  | —  | —  | ●   | ●   | ●   |
| Sensitivity adjustment                      | ●  | ●  | —   | —   | ●   |
| Electricity detection over coated wire (AC) | ●*   | ●*   | —   | —   | ●*  |
| function of LED light                       | —  | ●  | —   | ●   | —   |
| Waterproof                                  | —  | —  | ●   | ●   | —   |
| Voltage Discrimination Function             | —  | —  | —   | —   | ●<br>With insulated wire                                |
| Battery                                     | 2 alkaline button cells LR44(1.5V)<br>◦ Standard model | 2 alkaline button cells LR44(1.5V)<br>◦ With LED | AAA battery (R03/LR03 1.5V) × 1pce<br>◦ AC/DC type (only for bare wire) | AAA battery (R03/LR03 1.5V) × 1pce<br>◦ With LED    | LR44(1.5V) × 2pcs<br>◦ Switchable sensitivity (AC only) |

※Cables with a shield, conductive shielding layer, cannot be detected.

## For Medium/Low Voltage

| Model                 | For AC Voltage Detector for Medium/Low Voltage | For AC Voltage Detector for Medium/Low Voltage    | For AC Voltage Detector for Medium/Low Voltage | For AC Telescopic Type of Voltage Detector for Medium/Low Voltage | For AC & DC Telescopic Type of Voltage Detector for Medium/Low Voltage                                   | For AC & DC Medium Voltage Detector  |
|-----------------------|--|---|--|---|--|--|
|                       | HSF-11   | HSE-7G  | HSS-25B1                                       | HSS-36B1  | HSN-6A2  | HST-1.5N   |
| Working voltage range | AC80V~11.4kV                                   | AC60V~7kV   | AC80V~25kV                                     | AC80V~36kV  | AC80V to 7kV (at withstand voltage test of 10.5 kV)<br>DC50V to 7kV (at withstand voltage test of 21 kV) | AC600V~7kV<br>DC600V~7kV   |
| AC                    | ●  | ●   | ●  | ●   | ●  | ●  |
| DC                    | —  | —   | —  | —   | ●  | ●  |
| Telescopic type       | —  | —   | ●  | ●   | ●  | —  |
| Battery               | R03(1.5V) × 2pcs                               | LR44(1.5V) × 2pcs                                 | LR44(1.5V) × 2pcs                              | LR44(1.5V) × 2pcs   | LR44(1.5V) × 2pcs  | LR44(1.5V) × 2pcs  |
| Accessory             | Storage case<br>◦ Easy to handle and carry     | Storage case<br>◦ Recommended for telecom workers | Storage case<br>◦ Easy to handle and carry     | Storage case (option)<br>◦ Wide range type                        | Storage case (option)<br>◦ AC/DC type  | Storage case (option)<br>◦ Robust and lightweight FRP for insulating stick |

※Cables with a shield, conductive shielding layer, cannot be detected.

## For Medium/High Voltage

| Model                 | For AC & DC Medium Voltage Detector  | For AC Medium Voltage & High Voltage Detector                           | For AC Medium Voltage & High Voltage Detector  | For AC Medium Voltage & High Voltage Detector                            | For AC & DC Medium Voltage & High Voltage Detector | For AC High Voltage Detector                                       | For AC Pinwheel Type Voltage Detector   | For AC Non-contact Voltage Detector                                  | For AC Medium Voltage Detector   | For AC Medium Voltage Detector   |
|-----------------------|--------------------------------------|---|--|--|--|--|---|--|--|--|
|                       | HST-20N                              | HST-V series  | HST series   | HST-L series   | HSR-90N  | HSR-500  | WM series   | HWB series   | HWA-33X  | HWA-33P  |
| Working voltage range | AC3kV~25kV<br>DC3kV~25kV             | HST-35V AC 6kV~35kV<br>HST-138V AC 66kV~138kV<br>HST-550V AC210kV~550kV | HST-30 AC 3kV~34.5kV<br>HST-30W AC 3kV~42kV<br>HST-70 AC 20kV~80.5kV<br>HST-170 AC 60kV~195.5kV<br>HST-250 AC150kV~287.5kV | HST-30L AC 3kV~34.5kV<br>HST-70L AC20kV~80.5kV<br>HST-W80L AC20kV~80.5kV | AC6kV~90kV<br>DC6kV~90kV                           | AC250kV~550kV  | WM-22 AC 6kV~22kV<br>WM-33 AC 6kV~33kV<br>WM-77 AC11kV~77kV<br>WM-154 AC11kV~154kV<br>WM-275 AC33kV~275kV | HWB-35 AC 6kV~35kV<br>HWB-138 AC 66kV~138kV<br>HWB-550 AC210kV~550kV | AC 11kV~33kV   | AC 1kV~35kV  |
| AC                    | ●                                    | ●   | ●  | ●  | ●  | ●  | ●   | ●  | ●  | ●  |
| DC                    | ●                                    | —   | —  | —  | ●  | —  | —   | —  | —  | —  |
| Accessory             | Bag for housing grounding wire (7 m) | Bag for housing   | Bag for housing  | Bag for housing  | Bag for housing grounding wire (7 m)               | Bag for housing  | Bag for housing   | —  | Trunk case   | Trunk case   |
| Waterproof            | ●                                    | ●   | ●  | ●  | ●  | ●  | ●   | ●  | ●  | ●  |
| Telescopic type       | —                                    | —   | ●  | ●  | —  | ●  | ●   | —  | —  | —  |
| Battery               | LR44(1.5V) × 2 pcs<br>◦ AC/DC type   | LR44(1.5V) × 2pcs<br>◦ Universal joint type                             | LR44(1.5V) × 2pcs<br>◦ Lightweight & outstanding in operability  | LR44(1.5V) × 2pcs<br>◦ Long insulating stick type                        | 2 AAA batteries<br>◦ Wide range type for AC/DC     | 2 AAA batteries<br>◦ Voltage detector for 500kV transmission lines | Battery-less<br>◦ Battery-less voltage detector operating with energy                                     | R03 (1.5V) × 2pcs<br>◦ Non contact type, universal joint             | AAA alkaline batteries (LR03 1.5 V): 2 pieces<br>* Use of rechargeable batteries not allowed<br>◦ IEC61243-1 | AAA alkaline batteries (LR03 1.5 V): 2 pieces<br>* Use of rechargeable batteries not allowed<br>◦ Detector with 4 voltage indication |

※Cables with a shield, conductive shielding layer, cannot be detected.

# HTE-610W

Low Voltage Detector  
**volcheck**

AC 50V~1kV



## Low Voltage Detector Standard Model



### ■Features

- Highly convenient
  - Voltage detection through covering (sheath)
  - Sensitivity adjustment
- Designed with user safety and security in mind
  - Conductive rubber provides a high level of safety
  - CAT III 1000V

### ■Dimensions: HTE-610W

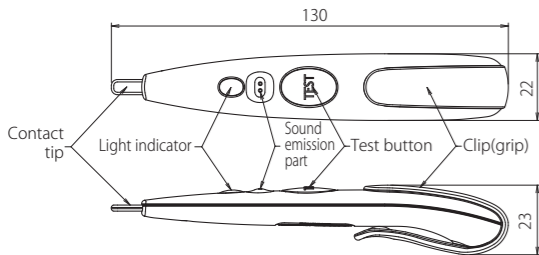

### ■Specifications

|  |   |
|--|---|
| Model  | HTE-610W  |
| Working voltage range                          | AC50V~1kV 50/60Hz   |
| Insulation resistance                          | Between contact tip and clip(grip): 100MΩ minimum with a 500V megger  |
| Dielectric strength                            | Ditto:2kV-1 minute  |
| Leakage current                                | Ditto:100 μA maximum  |
| Impulse withstand                              | Ditto:8000V-10 cycles of positive / negative (IEC61010-1 CAT III 1000V equivalent)  |
| Operation starting voltage (Voltage to ground) | Maximum sensitivity: AC40V maximum<br>Minimum sensitivity: Not operation at AC100V<br>Operation at AC200V<br>Ex-Factory: AC40V±10V<br>(when the contact tip is in contact with an internal standard insulated cable (600V-IV2mm <sup>2</sup> )) |
| Operation status display                       | Light: Intermittent red light visible in 8000lx ambient<br>Sound: Intermittent sound of 50dB minimum in 30cm distance   |
| Operating temperature range                    | 0°C ~ +40°C   |
| Wight  | 22g(including batteries)  |
| Battery  | 2 alkaline button cells LR44(1.5V)  |
| Battery life                                   | New battery : In continuous operation 10 hours<br>: In storage 1.5 years  |

# HTE-610WL

Low Voltage Detector  
**volcheck**

AC 50V~1kV



## Low Voltage Detector Standard Model



### ■Features

- Highly convenient
  - Voltage detection through covering (sheath)
  - Sensitivity adjustment
- Designed with user safety and security in mind
  - Conductive rubber provides a high level of safety
  - CAT III 1000V
- LED light type with more functions
  - Built in LED light with auto power-off function
  - The LED light also serves as a battery lever checker

### ■Dimensions: HTE-610WL

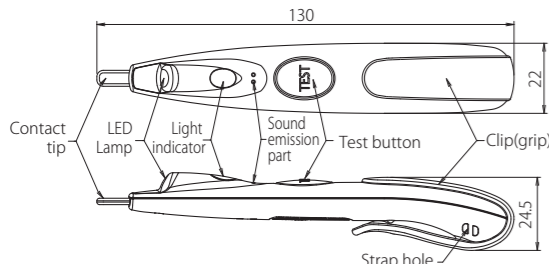

### ■Specifications

|  |   |
|--|---|
| Model  | HTE-610WL   |
| Working voltage range                          | AC50V~1kV 50/60Hz   |
| Insulation resistance                          | Between contact tip and clip(grip): 100MΩ minimum with a 500V megger  |
| Dielectric strength                            | Ditto:2kV-1 minute  |
| Leakage current                                | Ditto:100 μA maximum  |
| Impulse withstand                              | Ditto:8000V-10 cycles of positive / negative (IEC61010-1 CAT III 1000V equivalent)  |
| Lighting (HTE-610WL only)                      | The light is switched "ON" or "OFF" by pushing the test button.<br>The light is turned off automatically about 30 seconds after the light is turned on. (Automatic power off)<br>※The voltage detector operator regardless of the light turned ON or OFF. |
| Operation starting voltage (Voltage to ground) | Maximum sensitivity: AC40V maximum<br>Minimum sensitivity: Not operation at AC100V<br>Operation at AC200V<br>Ex-Factory: AC40V±10V<br>(when the contact tip is in contact with an internal standard insulated cable (600V-IV2mm <sup>2</sup> ))           |
| Operation status display                       | Light: Intermittent red light visible in 8000lx ambient<br>Sound: Intermittent sound of 50dB minimum in 30cm distance   |
| Operating temperature range                    | 0°C ~ +40°C   |
| Wight  | 22g(including batteries)  |
| Battery  | 2 alkaline button cells LR44(1.5V)  |
| Battery life                                   | New battery : In continuous operation 10 hours (with LED Lamp OFF)<br>5 hours (with LED Lamp ON)<br>: In storage 1.5 years  |

## How to use the LV voltage detector for AC

### ■Perform voltage detection while holding the grip firmly.

The contact area with the hand affects the sensitivity of the low voltage detector. So, appropriate sensitivity cannot be obtained unless it is held firmly.



### ■How to make contact with the detector

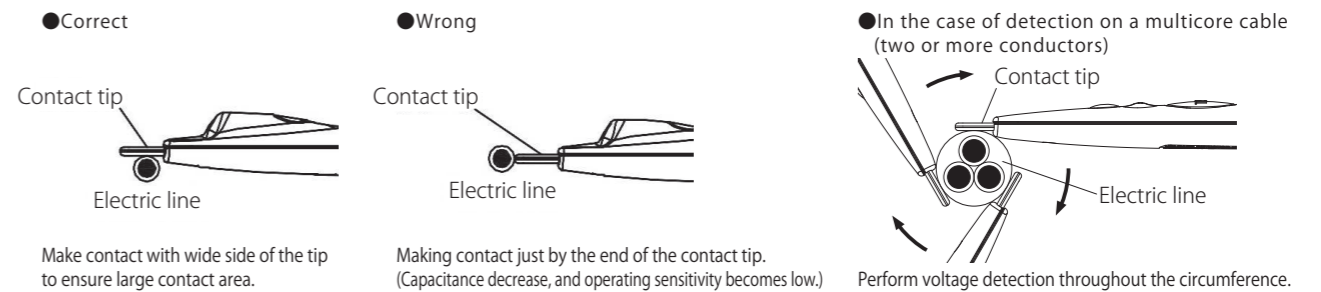

### ■Voltage detection for shielded cables is not possible.

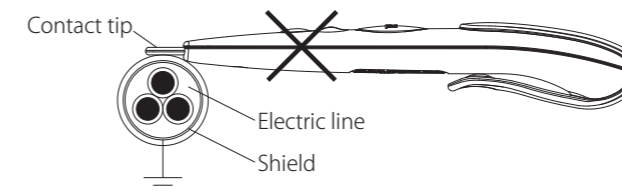

The voltage detector does not work because of the electrical shielding layer which is grounded.

### ■Sensitivity adjustment ( for HTE-610W, HTE-610WL, HT-670 ) \* Adjustment is made by the volume knob after detaching the clip.

The products are adjusted to the standard sensitivity at shipment (as default). However, sensitivity adjustment can be made when it is required for some reasons such as: When the detection is not possible over the outer surface of the insulated cable; When it is required to reduce the influence of induced voltage of the area etc.

When the volume knob is turned to the LV side (left turn), sensitivity increases (detect lower voltage), and when turned to the HV side (right turn), sensitivity decreases (detect higher voltage).

\* The volume knob can be turned only about half a rotation. Overturning may cause damage.

\* Pay attention to excessively high or low sensitivity. If it is excessively high, there is a risk that an correct judgment would not be possible, because the product responds to too small voltage and static electricity etc.

#### ■HTE-610W/610WL

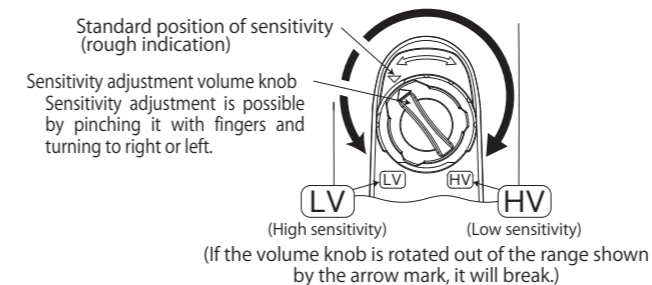

#### ■HT-670

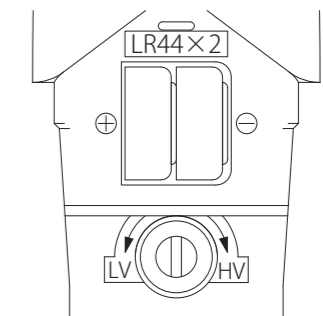

# HTE-700D/DL

Low Voltage Detector

**AC** 50V~600V  
**DC** 12V~750V



### Features

Waterproof equivalent to IPX4

### Dimensions

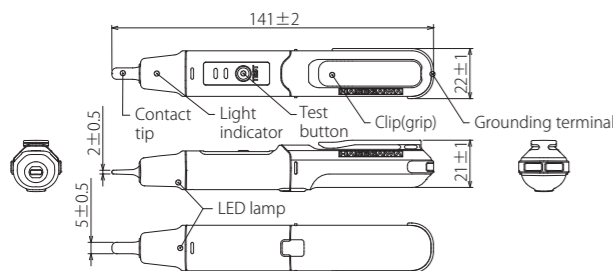

## The New release equipped waterproof as a successor of HT-680 Series



### Specifications

| Model  | HTE-700D   | HTE-700DL   |
|--|--|---|
| Working voltage range                          | AC   | 50V~600V  |
|  | DC   | 12V~750V  |
| Frequency                                      | 50/60Hz  |   |
| Operation starting voltage (Voltage to ground) | AC   | AC15V±5V DC6V±3V  |
|  | DC   | Hold to grounding terminal by bare hands or connect a grounding wire to the ground (company standard). AC 80V or less grounding wire is necessary to detect DC. |
| function of LED light                          | -  | ○   |
| Operation status indication                    | Light  | Continuous light emission in red : Verifiable at 8000lx   |
|  | Sound  | Continuous sound : 50dB or more (10cm apart)  |
| Operation temperature range                    | -10°C~+40°C  |   |
| Waterproof                                     | equivalent to IPX4   |   |
| Battery  | AAA battery (R03/LR03 1.5V) × 1 pce (Can not use rechargeable battery) |   |
| Battery life (with new battery)                | with LED   | about 10hr (under continuously operating state)   |
|  | without LED  | about 1.5years (in unused state)  |
| Weight   | about 25g (except battery)   |   |

# HT-670

Low Voltage Detector

**AC** 50V~600V  
**DC** 50V~600V



### Features

Sensitivity switch-over by slider switch depending on the detection (bare conductor/insulated conductor)

### Option

Lead wire/DF01027  
Optional lead wire can be used for  
• Voltage discrimination function (discrimination of 100 V, 200 V)  
• Prevents unnecessary detection due to reverse induction voltage (Lead wire should be contacted to grounded metal)

### Dimensions

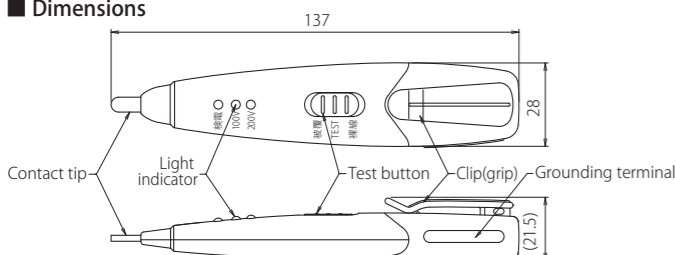

## Switchable sensitivity (AC only)



### Specifications

| Model  | Without lead wire              | With lead wire  |
|--|--------------------------------|---|
| Working voltage range                          | AC                             | 50V~600V  |
|  | DC                             | 50V~600V  |
| Frequency                                      | 50/60Hz                        |   |
| Operation starting voltage (Voltage to ground) | Coated wire (sheathed wire)    | AC 40 V with insulated wire (IV. 2 mm <sup>2</sup> ) (intermittent operation) |
|  | Bare wire                      | AC 30 ± 15 V (continuous operation)   |
|  | (At connection of lead wire)   | AC 100 V LED light 30 V ± 20 V (continuous operation)                         |
|  |                                | DC 200 V LED light 140 V ± 30 V (continuous operation)                        |
| Battery  | LR44(1.5V) × 2 pcs             |   |
| Battery life                                   | About one year with normal use |   |
| Weight   | 26g (except lead wire)         |   |

\* Without the casing

## How to use the LV Voltage Detector for DC

(For AC, refer to P.16.)

### Key points of DC voltage detection

When carrying out voltage detection with a DC circuit, the current does not flow through the capacitance, unlike the case of an AC circuit. Therefore, DC voltage detection becomes possible when the DC current flow through the detector by contacting the detector to an exposed charged conductor (\*①), connecting the earth terminal to the ground (\*②) and therefore creating a closed circuit (\*③).

- ① Voltage detection is not possible over the insulation. (Direct touch of contact tip to an exposed live part is necessary.)
- ② It is necessary to connect the Grounding terminal to earth with lead wire (option of HT-670) and/or with the free hand not holding the voltage detector.

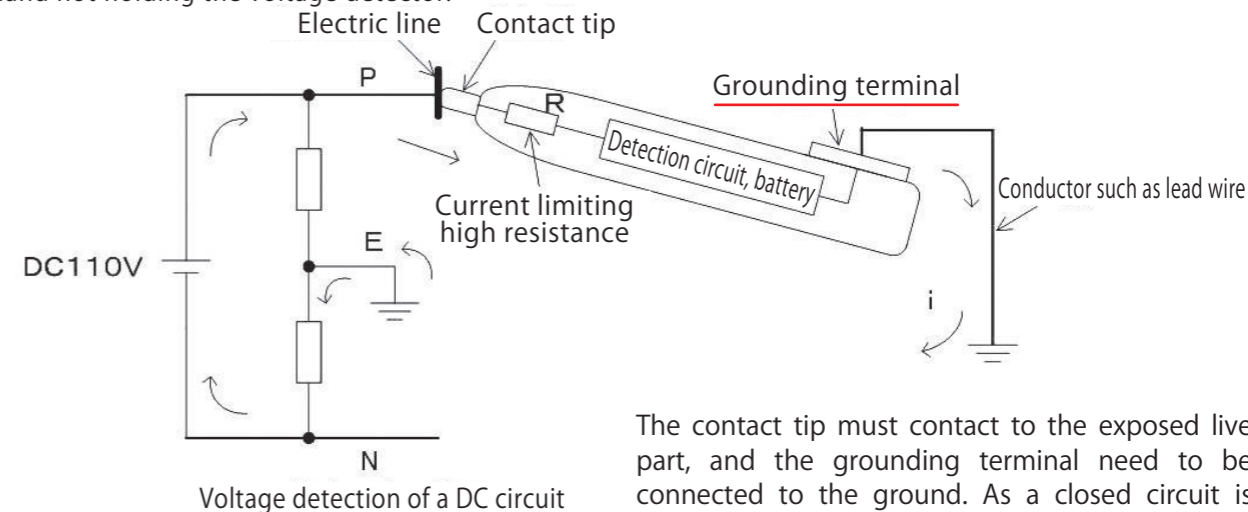

The contact tip must contact to the exposed live part, and the grounding terminal need to be connected to the ground. As a closed circuit is formed, a minute direct current flows.

- ③ Since the detected voltage between the live part and ground is depending on the condition of connection from grounding terminal to earth, it is necessary to understand about the circuit formed for detection. (cf. Voltage detection for un-earthed circuit is not possible.)

\* When HT-670 lead wire is used, the line-to-line voltage can be checked. (Pay sufficient attention to the handling of lead wires. There is a risk of electric shock and/or short-circuit if misused.)

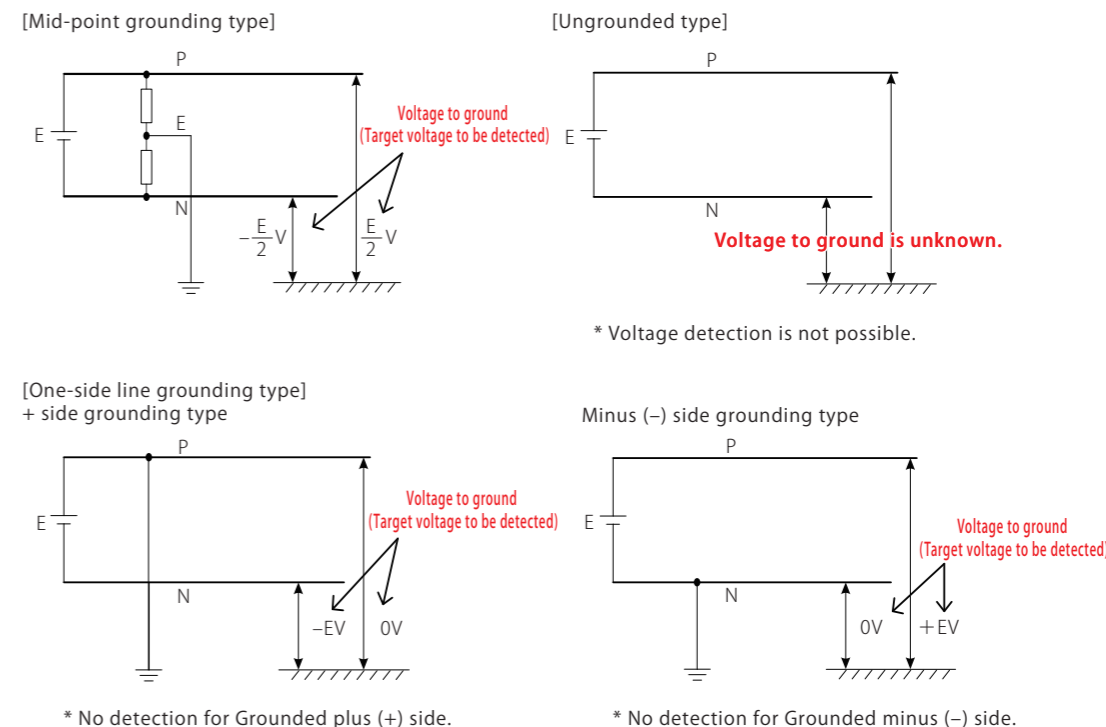

\* No detection for Grounded plus (+) side.

\* No detection for Grounded minus (-) side.

# HSF-11

Medium Voltage & Low Voltage Detector

AC 80V~11.4kV



### ■ Features

- Extremely small and light weighted, so easy to handle and carry.
- Voltage detection can be done by both light and sound, so no misconception happens.
- Testing system is equipped to Voltage Detector itself.
- By inner electric circuit, consumption is saved when not used.

### ■ Dimensions

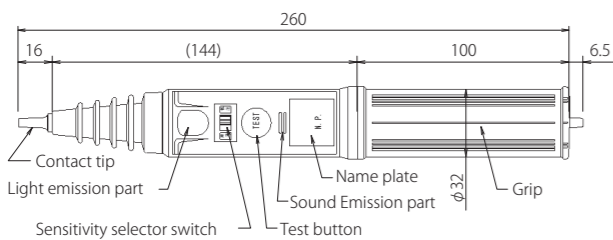

## Standard Model for 11.4kV



### ■ Accessory



Storage case

### ■ Specifications

|  |   |   |
|--|---|---|
| Working voltage range                          |   | AC80V~11.4kV  |
| Operation starting voltage (Voltage to ground) | Low voltage   | Exposed live part 65 ± 15V (in contact with live part)    |
|  | High voltage  | Exposed live part 2000 ± 200V (in contact with live part) |
| Electric line                                  | For Bare wire only  |   |
| Frequency                                      | Both 50Hz and 60Hz  |   |
| Dielectric strength                            | 20kV for 1minutes between the contact tip and the grip            |   |
| Leakage current                                | 0.1mA or less on dielectric strength                              |   |
| Operation status display                       | Light emission  | Verifiable at 8000 Lx of brightness (Red LED)             |
|  | Sound emission  | 50 dB or more (2m apart)                                  |
| Operating temperature range                    | -10°C~+40°C   |   |
| Waterproof                                     | Equivalent to IPX3 (No harmful water entering inside)             |   |
| Battery  | R03(1.5V) 2pcs  |   |
| Battery life                                   | About 6 hr. under continuously operating state (with new battery) |   |
| Weight   | About 150 g   |   |

# HSE-7G

For communication

Medium Voltage & Low Voltage Detector

AC 60V~7kV



### ■ Features

- Working voltage range from AC 60V as per Telecom standard in Japan
- Successor of HSC-7G (certified product as per NTT spec.)

### ■ Dimensions

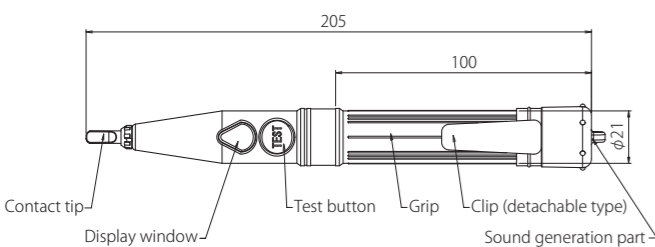

## Recommended for Telecom workers on the pole



### ■ Accessory



Storage case

### ■ Option



Contact tip for replacement (UH05004)

### ■ Specifications

|  |  |   |
|--|--|---|
| Working voltage range                          |  | AC60V~7kV   |
| Operation starting voltage (Voltage to ground) | Low voltage  | Exposed live part 60 V (in contact with live part)  |
|  | High voltage   | Exposed live part 400 V (in contact with live part) |
| Frequency                                      | 50/60Hz  |   |
| Dielectric strength                            | 20 kV for 1 min between contact tip and grip                         |   |
| Leakage current                                | 0.5 mA or less at dielectric strength test                           |   |
| Battery  | LR44(1.5V) × 2 pcs   |   |
| Battery life                                   | 3 hr. in continuously operating state; about 2 years in unused state |   |
| Operating temperature range                    | -10°C~+40°C  |   |
| Weight   | About 55 g   |   |

# HSS-25B1

Medium Voltage & Low Voltage Detector

AC 80V~25kV



### ■ Features

- Voltage detection from a remote place is possible by extending it
- \* Low voltage cannot be detected on stick extension mode.

### ■ Dimensions

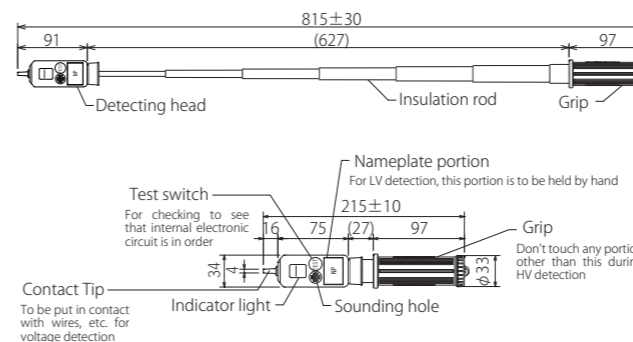

## Telescopic type, Standard model for Medium Voltage



### ■ Accessory



Storage case

### ■ Detecting at low voltage

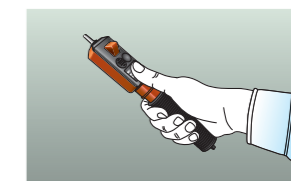

### ■ Specifications

|  |  |  |
|--|--|--|
| Working voltage range                          |  | AC80V~25kV   |
| Operation starting voltage (Voltage to ground) | Low voltage  | Bare wire : AC 80V or below (Detect holding nameplate portion)                                 |
|  | High voltage   | Bare wire (φ3mm) : AC 250V ± 50V<br>OC wire (φ5mm) : AC 1000V ± 200V (Detect holding the grip) |
| Frequency                                      | 50/60Hz  |  |
| Dielectric strength                            | Between contact tip and grip: Extended state 50 kVAC, 1 min<br>Between contact tip and name plate portion: 4 kVAC, 1 min |  |
| Leakage current                                | 0.1 mA or less at dielectric strength test   |  |
| Battery  | LR44(1.5V) × 2 pcs   |  |
| Battery life                                   | 8 hr. in continuously operating state; about 1.5 years in unused state   |  |
| Operating temperature range                    | -10°C~+50°C  |  |
| Weight   | About 140 g  |  |

# HSS-36B1

Medium Voltage & Low Voltage Detector

AC 80V~36kV



### ■ Features

- Voltage detection from a remote place is possible by extending it
- \* Low voltage cannot be detected on stick extension mode.

### ■ Dimensions

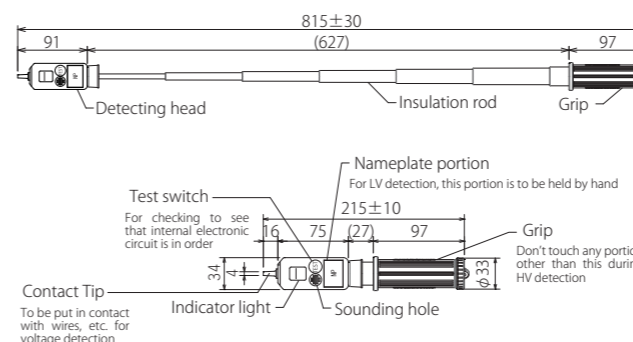

## New release with expanded voltage range



### ■ Option



Storage case

### ■ Detecting at low voltage

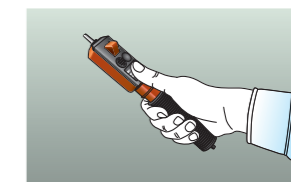

### ■ Specifications

|  |  |  |
|--|--|--|
| Working voltage range                          |  | AC80V~36kV   |
| Operation starting voltage (Voltage to ground) | Low voltage  | Bare wire : AC 80V or below (Detect holding nameplate portion)                                 |
|  | High voltage   | Bare wire (φ3mm) : AC 250V ± 50V<br>OC wire (φ5mm) : AC 1000V ± 200V (Detect holding the grip) |
| Frequency                                      | 50/60Hz  |  |
| Dielectric strength                            | Between contact tip and grip: Extended state 72 kVAC, 1 min<br>Between contact tip and name plate portion: 4 kVAC, 1 min |  |
| Leakage current                                | 0.1 mA or less at dielectric strength test   |  |
| Battery  | LR44(1.5V) × 2 pcs   |  |
| Battery life                                   | 8 hr. in continuously operating state; about 1.5 years in unused state   |  |
| Operating temperature range                    | -10°C~+50°C  |  |
| Weight   | About 140 g  |  |

# HSN-6A2

Medium Voltage & Low Voltage Detector

**AC** 80V to 7kV (at withstand voltage test of 10.5kV)  
**DC** 50V to 7kV (at withstand voltage test of 21kV)



### Features

- It can be used for withstand voltage tests with high-voltage equipment. It can be used up to 10.5 kVAC, 21 kVDC, only for application of withstand voltage test.
- Discriminate AC and DC
- Checking residual electric charge, and discharging it. (Refer to P.66.)

### Dimensions

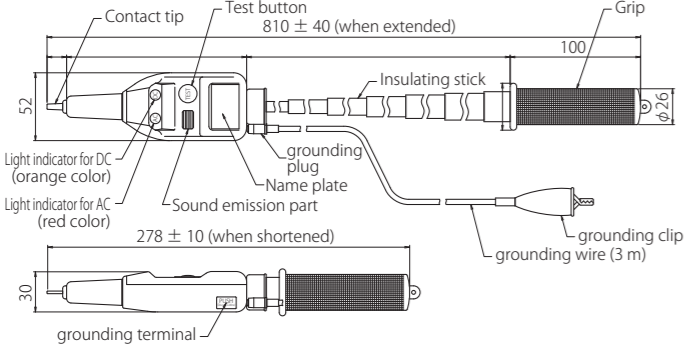

### Accessory



Storage case

### Detecting at low voltage

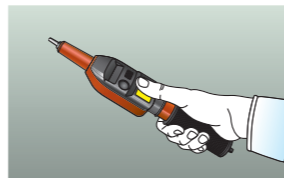

### Specifications

|                                       |   |    |   |
|---------------------------------------|---|----|---|
| Working voltage range                 | Without grounding wire                                      | AC | 80 V to 600 V (Voltage detection by touching the name plate with a hand)  |
|                                       | With grounding wire   | AC | 3 kV to 7 kV (With extended insulating stick)   |
| Frequency                             | AC  |    | 80 V to 7 kV (Usable up to 10.5 kV for withstand voltage test)  |
|                                       | DC  |    | 50 V to 7 kV (Usable up to 21 kV for withstand voltage test)  |
| Dielectric strength & Leakage current | Between contact tip and name plate                          |    | 4 kVAC, 1 min, 0.5 mA or less   |
|                                       | Between contact tip and grip                                |    | (Insulating stick: Shortened) 20 kVAC, 1 min, 0.5 mA or less<br>(Insulating stick: Extended) 50 kVAC, 1 min, 0.5 mA or less |
|                                       | Between contact tip and grounding clip                      |    | 21 kVDC, 1 min, 0.5 mA or less  |
|                                       | Between core of the grounding plug and outside the covering |    | 21 kVDC, 1 min  |
| Battery                               |   |    | LR44(1.5V) × 2 pcs  |
| Operating temperature range           |   |    | -10°C ~ +50°C   |
| Weight                                |   |    | About 290 g   |

# HST-1.5N

Medium Voltage Detector

**AC** 600V~7kV  
**DC** 600V~7kV



### Features

- With 7-m grounding wire

### Dimensions

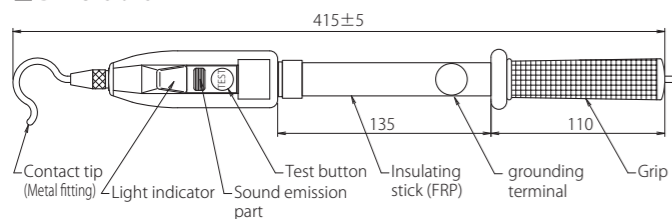

### Accessory



Bag for housing



grounding wire (7 m)

### Specifications

|                             |    |   |
|-----------------------------|----|---|
| Working voltage range       | AC | 600V~7kV  |
|                             | DC | 600V~7kV  |
| Frequency                   |    | 50/60Hz   |
| Dielectric strength         |    | Between contact tip and grounding terminal 14000 VAC, 5 min |
| Leakage current             |    | 1 mA or less at dielectric strength test                    |
| Battery                     |    | LR44(1.5V) × 2 pcs  |
| Battery life                |    | 4 hr. under continuously operating state                    |
| Operating temperature range |    | -10°C ~ +40°C   |
| Weight                      |    | About 340 g (main body only)                                |

## Robust and Lightweight, FRP for Insulating Stick



# HST-20N

Medium Voltage Detector

**AC** 3kV~25kV  
**DC** 3kV~25kV



### Features

- New model with reduced weight of HS-20N

### Dimensions

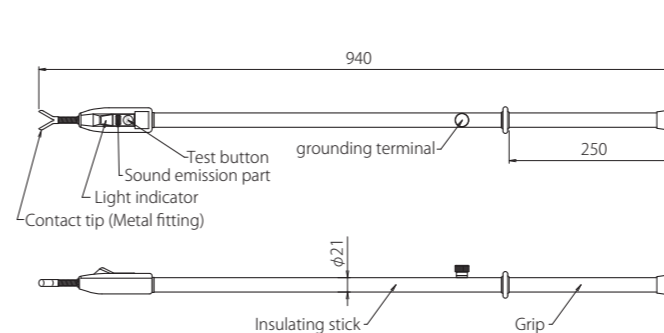

### Accessory



Bag for housing



grounding wire (7 m)

### Specifications

|  |    |  |
|--|----|--|
| Working voltage range                          | AC | 3kV~25kV   |
|  | DC | 3kV~25kV   |
| Operation starting voltage (Voltage to ground) | AC | 1000V ± 20%  |
|  | DC | Unusable   |
| Frequency                                      |    | 50/60Hz  |
| Dielectric strength                            |    | Between contact tip and grounding terminal, AC 50kV, 1 min |
| Leakage current                                |    | 0.5 mA or less at dielectric strength test                 |
| Battery  |    | LR44(1.5V) × 2 pcs   |
| Battery life                                   |    | About 4 hr. in a continuously operating state              |
| Operating temperature range                    |    | -10°C ~ +40°C  |
| Weight   |    | About 610 g (main body only)                               |

# HST-V series

HST-35V/HST-138V/HST-550V  
 Medium Voltage & High Voltage Detector

**AC** HST-35V 6kV~35kV  
 HST-138V 66kV~138kV  
 HST-550V 210kV~550kV



### Features

- This product is for AC current, and it indicates the presence of charge in circuits with an electronic buzzer that is easy to hear and a high-luminance light emitting diode. It is light-weight and easy to handle.

### Dimensions

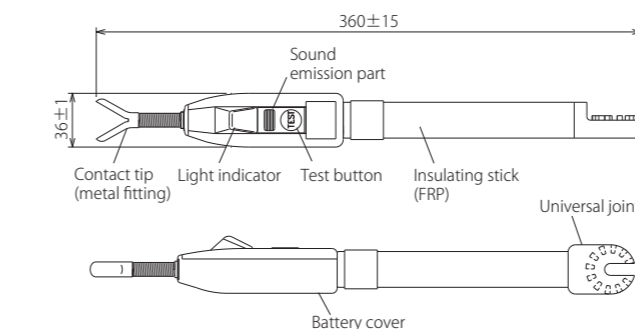

## Universal Joint Type



### Accessory



Bag for housing

### Specifications

|                             |          |   |             |
|-----------------------------|----------|---|-------------|
| Model                       | HST-35V  | HST-138V                                      | HST-550V    |
| Working voltage range       | 6kV~35kV | 66kV~138kV                                    | 210kV~550kV |
| Indication                  | Sound    | Intermittent sound 70dB or more               |             |
|                             | Light    | Verifiable at 8,000lx of brightness (Red LED) |             |
| Frequency                   |          | 50/60Hz                                       |             |
| Water proof                 |          | Equivalent to IPX3                            |             |
| Operating temperature range |          | -10°C ~ +50°C                                 |             |
| Battery                     |          | LR44 (1.5V) × 2 pcs.                          |             |
| Accessory                   |          | Bag for housing                               |             |
| Weight                      |          | About 220 g                                   |             |

# HST series

HST-30/HST-30W/HST-70/HST-170/HST-250  
Medium Voltage & High Voltage Detector

|    |         |               |
|----|---------|---------------|
| AC | HST-30  | 3kV~34.5kV    |
|    | HST-30W | 3kV~42kV      |
|    | HST-70  | 20kV~80.5kV   |
|    | HST-170 | 60kV~195.5kV  |
|    | HST-250 | 150kV~287.5kV |



### ■ Features

- FRP is used for the insulating stick. It is lightweight and outstanding in operability.
- Tip metal fitting consists of a shock-absorbing spring.

### ■ Dimensions

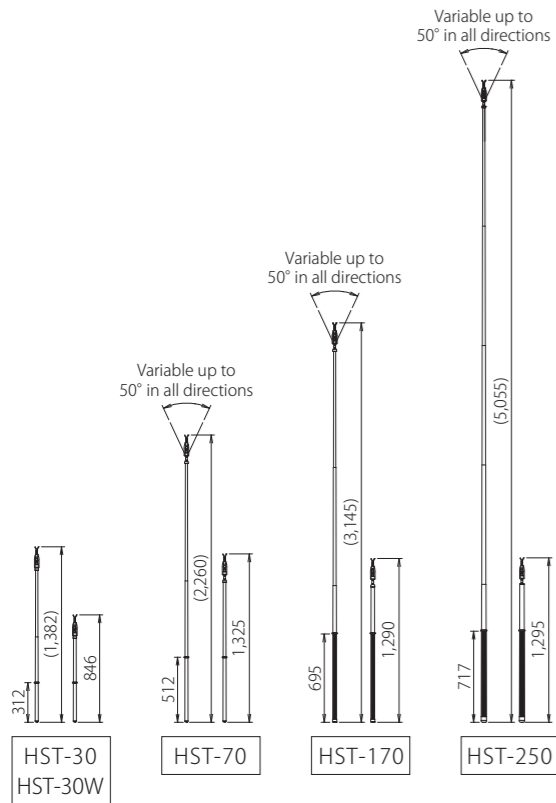

Because the angle at the detector is adjustable, it can be set up so that the light emission is easy to see. (HST-70, HST-170, HST-250)

### ■ Accessory



HST-30 (Shortened state) HST-170 (Shortened state)

■ Operating rod can be changed to a longer one. (\* Changing to a shorter one is not possible from the viewpoint of safety.)

| Model   | Standard product | Model after changing the operating rod        |  |  |
|---------|------------------|---|--|--|
|         |                  | Changed to operating rod of HST-70 (2,260 mm) | Changed to operating rod of HST-170 (3,145 mm) | Changed to operating rod of HST-250 (5,055 mm) |
| HST-30  |                  | HST-30G                                       | HST-30H  | HST-30J  |
| HST-70  |                  | —   | HST-70H  | HST-70J  |
| HST-170 |                  | *   | —  | HST-170J                                       |

### ■ Specifications

| Model  | HST-30  | HST-30W  | HST-70   | HST-170      | HST-250       |
|--|---|--|--|--------------|---------------|
| Working voltage range                          | AC 3kV~34.5kV                                   | 3kV~42kV   | 20kV~80.5kV  | 60kV~195.5kV | 150kV~287.5kV |
| Operation starting voltage (Voltage to ground) | Bare wire 500V±20%<br>φ5mm-OC wire 3 kV or less | AC 500 ± 100 V (bare wire)                               | 3kV±20%  | 10kV±20%     | 20kV±20%      |
| Frequency                                      | 50/60Hz   |  |  |              |               |
| Dielectric strength                            | Contact tip – Grip 70 kVAC, 1 min               | On insulating rod AC 75kV/300mm for 1 minute. (2 places) | Insulating stick 75 kVAC/300 mm, 1 min (following positions except for the electrode and joint portions) |              |               |
| Battery  | LR44(1.5V) × 2 pcs                              |  |  |              |               |
| Operating temperature range                    | -10°C~+50°C                                     |  |  |              |               |
| Weight   | About 340 g                                     | About 530 g  | About 600 g  | About 1030 g |               |

# HST-L series

HST-30L/HST-70L/HST-W80L  
Medium Voltage & High Voltage Detector

|    |          |             |
|----|----------|-------------|
| AC | HST-30L  | 3kV~34.5kV  |
|    | HST-70L  | 20kV~80.5kV |
|    | HST-W80L | 20kV~80.5kV |



### ■ Features

- FRP is used for the insulating stick. It is lightweight and outstanding in operability.
- Tip metal fitting consists of a shock-absorbing spring.



Detecting part

## Detector with long insulating stick



### ■ Dimensions

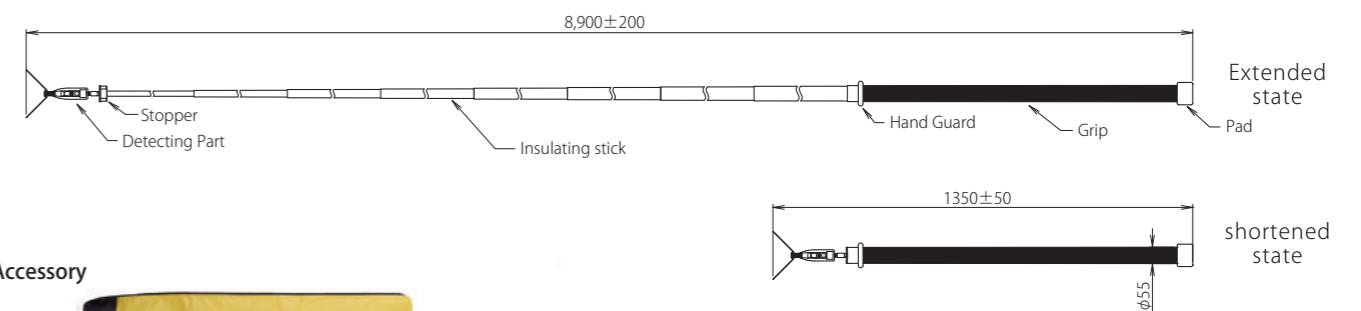

### ■ Accessory



Bag for housing (DA14006)

### ■ Specifications

| Type                        | HST-30L  | HST-70L     | HST-W80L      |
|-----------------------------|--|-------------|---------------|
| Working voltage range       | AC 3kV~34.5kV  | 20kV~80.5kV | 20kV~80.5kV   |
| Operation starting voltage  | AC 500V±100V   | 3,000V±600V | 5,000V±1,000V |
| Frequency                   | 50/60Hz  |             |               |
| Dielectric strength         | on insulating stick AC 75kV/300mm for 1 minute. (insulating stick excluding contact tip and joint) |             |               |
| Leakage current             | 0.1mA or less during dielectric strength test (1 place)  |             |               |
| Battery                     | LR44(1.5V) × 2 pcs   |             |               |
| Life of the battery         | About 4 hr. under continuously operating state   |             |               |
| Operating temperature range | -10°C~+50°C  |             |               |
| Weight                      | About 3kg  | About 3kg   | About 3kg     |

# HSR-90N

Medium Voltage and High Voltage Detector

AC 6kV~90kV  
DC 6kV~90kV



### ■ Features

- It operates over wide range from medium voltages to high voltages

### ■ Dimensions

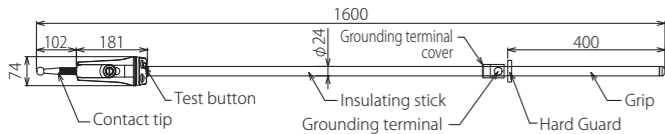

### ■ Specifications

|  |   |           |
|--|---|-----------|
| Working voltage range                          | AC  | 6kV~90kV  |
|  | DC  | 6kV~90kV  |
| Operation starting voltage (Voltage to ground) | AC  | 1000V±20% |
|  | DC  | 3000V±20% |
| Frequency                                      | 50/60Hz   |           |
| Dielectric strength                            | Between contact tip and grounding terminal, AC 180kV, 1 min |           |
| Battery  | 2 AAA batteries   |           |
| Operating temperature range                    | -10°C~+40°C   |           |
| Weight   | About 1.5 kg (main body only)                               |           |

## Wide Range type for both AC and DC



### ■ Accessory



# HSR-500

High Voltage Detector

AC 250kV~550kV



### ■ Features

- Voltage detector for the highest voltage T/L in Japan
- Sound and light indications can be confirmed outdoors in daytime, even in high level of noise.

### ■ Dimensions

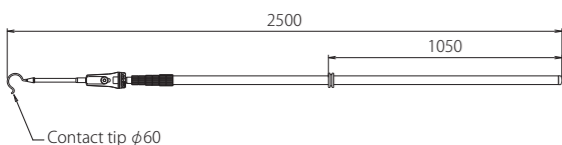
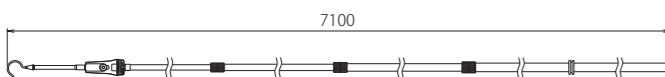

### ■ Accessory



Bag for housing

### ■ Specifications

|  |   |
|--|---|
| Working voltage range                          | AC250kV~550kV                                     |
| Operation starting voltage (Voltage to ground) | 20 kVAC ± 20% (in contact with exposed live part) |
| Dielectric strength                            | Insulation pole 75 kVAC/300 mm, 1 min             |
| Battery  | 2 AAA batteries                                   |
| Operating temperature range                    | -10°C~+40°C                                       |
| Weight   | About 4.5 kg                                      |

## Voltage Detector for 500 kV Transmission Lines



# WM series

WM-22/WM-33/WM-77A/WM-77B  
WM-154A/WM-77C/WM-154B/WM-275

Pinwheel Type Voltage Detector

AC 6.6kV~500kV



### ■ Features

- Battery-less voltage detector operating with energy to be detected.

### ■ Specifications

| model No. | Working Voltage Range (kV) | Length / parts (m) | quantity of parts | Length[Max] (m) | Length[Min] (m) | Rod Diameter (φ) | Weight (g) |
|-----------|----------------------------|--------------------|-------------------|-----------------|-----------------|------------------|------------|
| 22        | 6~ 22                      | 0.7                | 2                 | 1.51            | 0.91            | 20               | 340        |
| 33        | 6~ 33                      | 1.0                | 2                 | 2.11            | 1.21            | 20               | 440        |
| 77A       | 11~ 77                     | 1.0                | 2                 | 2.11            | 1.21            | 20               | 430        |
| 77B       | 11~ 77                     | 1.2                | 2                 | 2.51            | 1.41            | 20               | 490        |
| 77LB      | 11~ 77                     | 1.3                | 2                 | 2.71            | 1.51            | 20               | 530        |
| 77C       | 11~ 77                     | 1.2                | 3                 | 3.65            | 1.41            | 25               | 780        |
| 154A      | 11~154                     | 1.0                | 3                 | 3.04            | 1.21            | 25               | 660        |
| 154B      | 11~154                     | 1.3                | 3                 | 3.95            | 1.51            | 25               | 840        |
| 154D      | 11~154                     | 1.2                | 4                 | 4.78            | 1.41            | 30               | 1140       |
| 154E      | 11~154                     | 1.2                | 5                 | 5.81            | 1.41            | 35               | 1520       |
| 275       | 33~275                     | 1.2                | 4                 | 4.78            | 1.41            | 30               | 1130       |
| 275E      | 33~275                     | 1.2                | 5                 | 5.81            | 1.41            | 35               | 1510       |
| 275F      | 33~275                     | 1.2                | 6                 | 7.03            | 1.42            | 40               | 2030       |
| 500LF     | 154~500                    | 1.3                | 6                 | 7.61            | 1.52            | 40               | 2170       |
| 500G      | 154~500                    | 1.2                | 7                 | 8.16            | 1.42            | 45               | 2560       |

## Voltage Detection Check with Rotation of Pinwheel.



Contact tip (Metal fitting): Spring

# HWB series

Non-contact Voltage Detector

AC HWB-35 6kV~ 35kV  
HWB-138 66kV~138kV  
HWB-550 210kV~550kV



### ■ Features

- FRP is used for the insulating stick. It is of light-weight and has outstanding operability.
- Universal joint type

### ■ Specifications

| Model                       | HWB-35   | HWB-138  | HWB-550                |
|-----------------------------|--|--|------------------------|
| Working voltage range       | AC 6kV~35kV  | AC 66kV~138kV  | AC 210kV~550kV         |
| Operation distance          | 5 ~ 10cm (at AC 6kV)   | 5 ~ 10cm (at AC 66kV)  | 5 ~ 10cm (at AC 210kV) |
| Indication                  | Sound  | Intermittent sound 80dB or more  |                        |
|                             | Light  | Stand-by state : Green LED light (Automatically turns off in about 2minutes)<br>Operation state : Red LED flash light (Flashing red light, distinguishable in brightness of 50,000lux) |                        |
| Frequency                   | 50/60Hz  |  |                        |
| Water proof                 | Equivalent to IP45   |  |                        |
| General design              | Separate device  |  |                        |
| Shock resistance            | This device has Shock resistance by Pendulum method (Pendulum method : IEC 61243-1 Shock resistance) |  |                        |
| Operating temperature range | -10°C~+50°C  |  |                        |
| Battery                     | R03 (1.5V) × 2pcs.   |  |                        |
| Weight                      | About 400 g (Include batteries)  |  |                        |
| Accessory                   | Bag for housing  |  |                        |

## Non-Contact Type



### ■ Dimensions

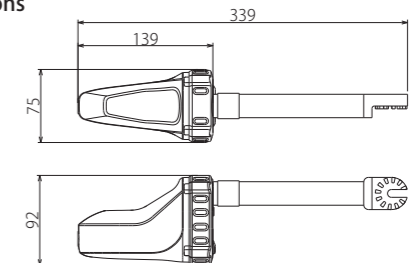

# HWA-33X

## Medium Voltage Detector

AC 11kV~33kV



### Features

This product emits light and sounds in **three stages** depending on the distance to the object.

### Dimensions

191 mm × 79 mm × φ64 mm

\*Length of the Y-shaped contact tip (metal fitting): 27 mm

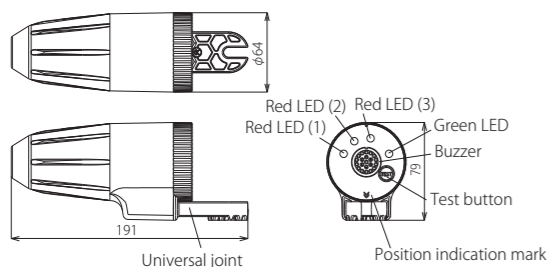

### Specifications

|                    |  |
|--------------------|--|
| Applicable voltage | 11 kV to 33 kV AC (With proximity alarm function)  |
| Frequency          | 50/60 Hz   |
| Battery            | AAA alkaline batteries (LR03 1.5 V): 2 pieces<br>* Use of rechargeable batteries not allowed |
| Sound volume       | 70dB or more   |
| Weight             | About 350 g (excluding the contact tip)  |
| Accessory          | Trunk case   |

\* HXA-33X includes the main unit and storage bag. The insulating stick is not included.

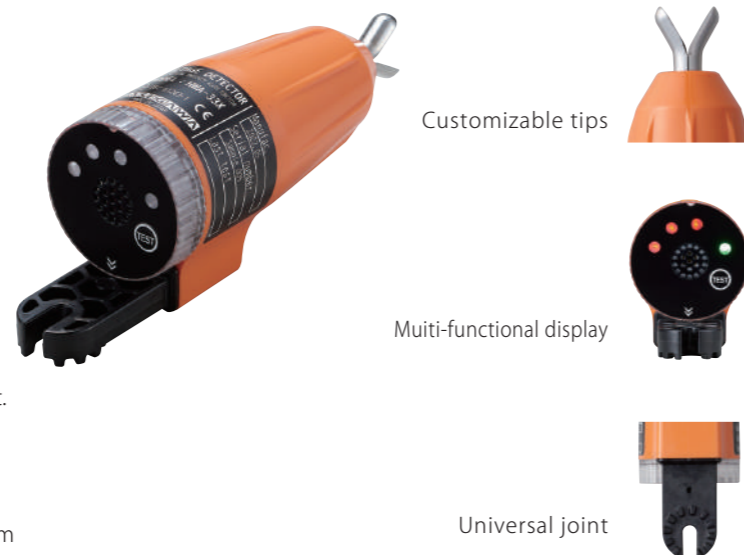

# HWA-33P

## Medium Voltage Detector

AC 1kV~35kV



### Features

This product emits light and sounds in **four stages** depending on the voltage of the object.

### Dimensions

191 mm × 79 mm × φ64 mm

\*Length of the Y-shaped contact tip (metal fitting): 27 mm

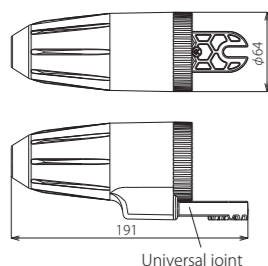

## Detector with 4 voltage indication

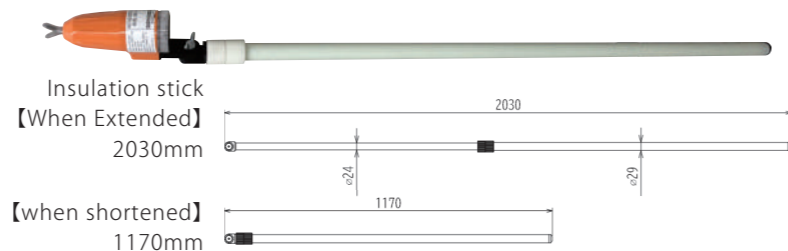
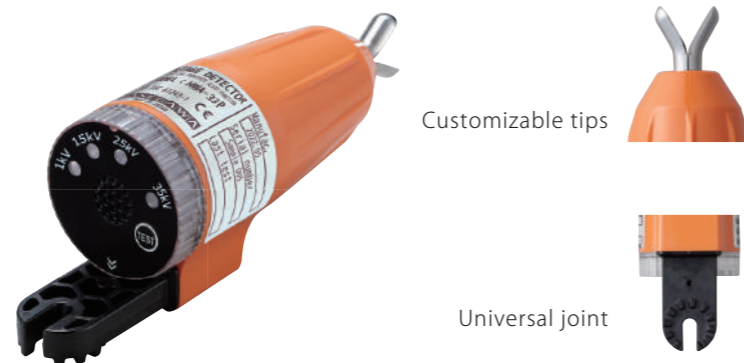

### Specifications

|                    |  |
|--------------------|--|
| Applicable voltage | 1 kV to 35 kV AC (4-step detection 1kV-15kV-25kV-35kV)                                       |
| Frequency          | 50/60 Hz   |
| Battery            | AAA alkaline batteries (LR03 1.5 V): 2 pieces<br>* Use of rechargeable batteries not allowed |
| Sound volume       | 70dB or more   |
| Weight             | About 1.2kg (Including insulating stick)   |
| Accessory          | Trunk case   |

\* HXA-33P includes the main unit, storage bag and insulating stick.

# HPL-200W

Low Voltage Phase Checker  
Insulated Wire Clamping Type

AC 70V~1kV (Three-Phase)

### Features

- Non-contact type: Phase rotation and in-phase/different phase can be checked from above insulated cables
- Electric line size: Wide range from 2 mm<sup>2</sup> - 100 mm<sup>2</sup> (Finished external diameter φ2.8 mm - 22 mm)
- The magnet attached on the rear of the product makes hands-free checking possible

### Specifications

|                       |   |
|-----------------------|---|
| Working voltage range | 3-phase 70V~1kV AC (Sinusoidal wave, continuous)  |
| Dielectric resistance | 100 MΩ or more, using 500 V megger (Between clip and case)  |
| Dielectric strength   | AC 2,000 V, one minute (Between clip and case)  |
| Leakage current       | During dielectric strength testing, 100 μA or less  |
| Power supply display  | Red LED × 1 (Automatic power OFF approx. 5 minutes)   |
| Sound volume          | 50 dB or more (50 cm apart)   |
| Battery               | LR03(1.5V) × 2<br>Continuous use approx. 15 hours   |
| Electric line         | IV, DV, OW 2 mm <sup>2</sup> to 100 mm <sup>2</sup> (Finished external diameter φ2.8 mm to 22 mm) |
| Weight                | About 190 g (including batteries)   |

### Indications

| Charge indication | LED color | Charged state (Voltage to ground of 80V or higher) | Power cut state, or *1, 2        |
|-------------------|-----------|--|----------------------------------|
|                   |           | R (Yellow), S (Yellow), T (Yellow)                 | Lighting                         |
|                   |           | *1 If voltage to ground is 80 V or lower           | *2 If ground phase or open-phase |

| Phase rotation indication | LED Flashing/Color | Positive rotation | Reversed rotation  |
|---------------------------|--------------------|-------------------|--------------------|
|                           |                    | Green             | Red                |
|                           |                    | —                 | Intermittent sound |

| In-phase and different phase indication (Charge indication) | LED color | In-phase                           | Different phase |
|---|-----------|------------------------------------|-----------------|
|   |           | R (Yellow), S (Yellow), T (Yellow) | Flashing        |
|   |           | Flashing                           | Lighting        |
| * Display of two clips used, light off when unused          |           |                                    |                 |

### Example indications

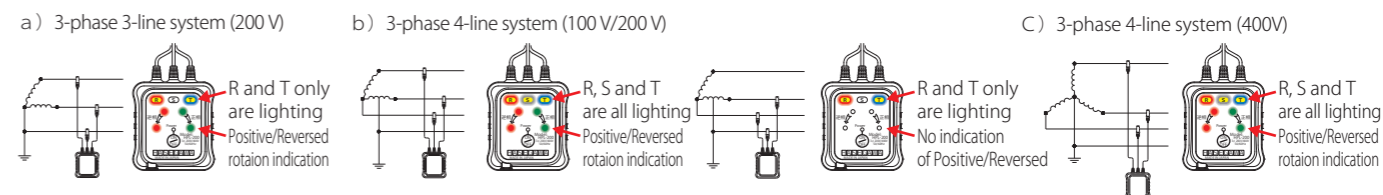

This one unit can be used for both in-phase and different phase checks



Connection method for in-phase and different phase checks  
Electric meter replacement work without power cut  
(Phase test before in-phase attachment of bypass cable)

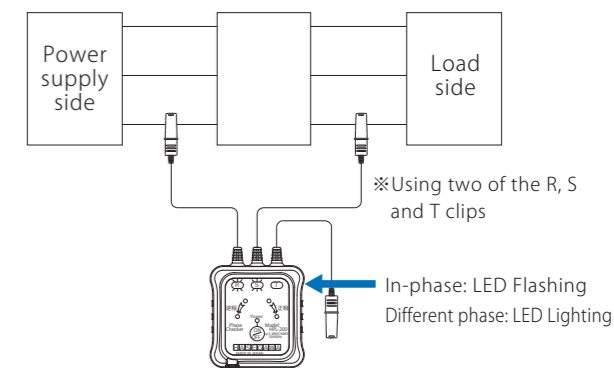

### Dimensions

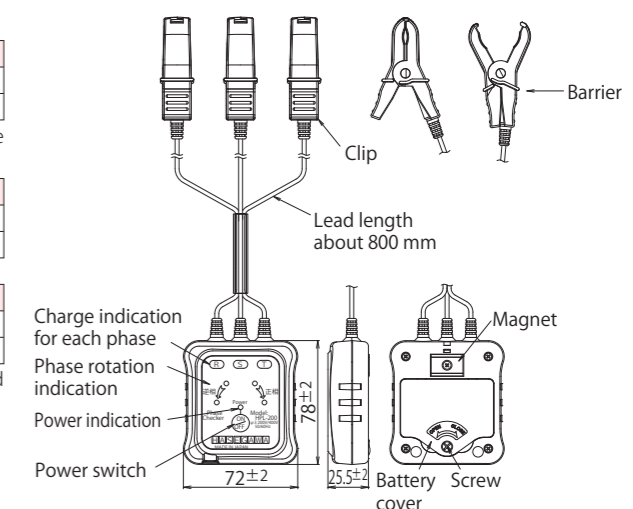

# HPI-A6/S6/S20W

Medium Voltage & High Voltage Phase Tester, Optical Fiber Type

- HPI-A6 AC 3kV~7kV
- HPI-S6 AC 6.6kV
- HPI-S20W AC 22kV~42kV

## Alarm pairs insulated with optical fiber

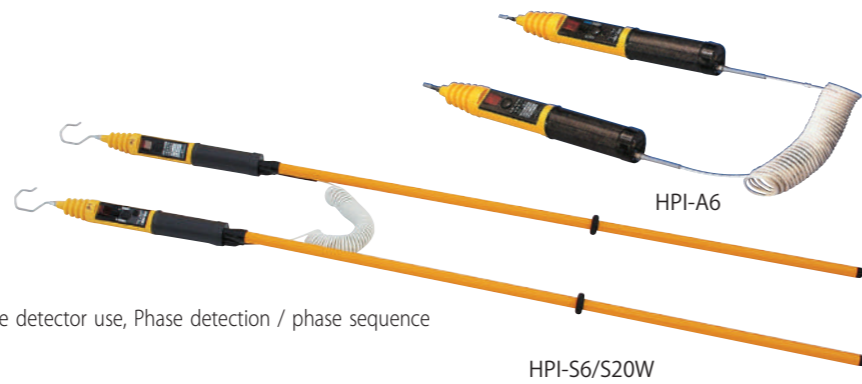

### Features

- Multi-functional phase tester: Voltage Detection by single detector use, Phase detection / phase sequence check with pair detector use
- Measurement is possible on the insulated wire sheath. Testing operation is possible through voltage detection terminals or on the wire insulation. \* Cannot be used on the shielded cable.
- In-phase/different phase, and phase sequence are indicated by sound and light indications.

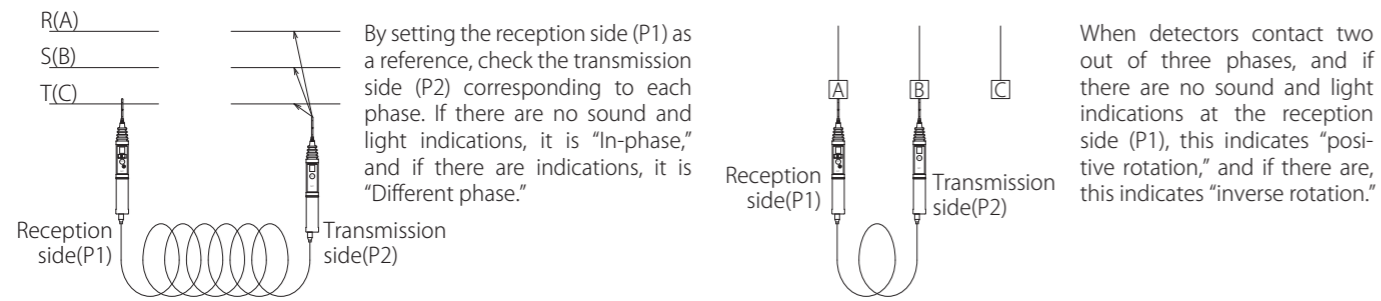

### Accessory

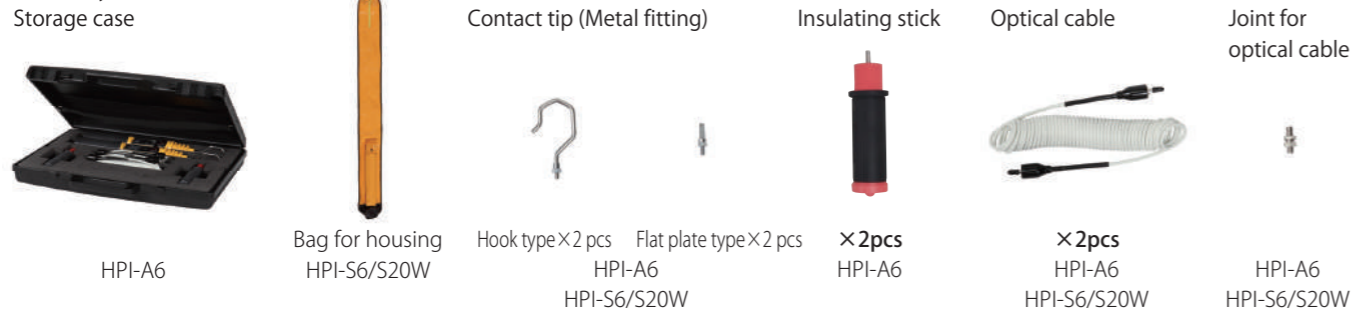

### Dimensions

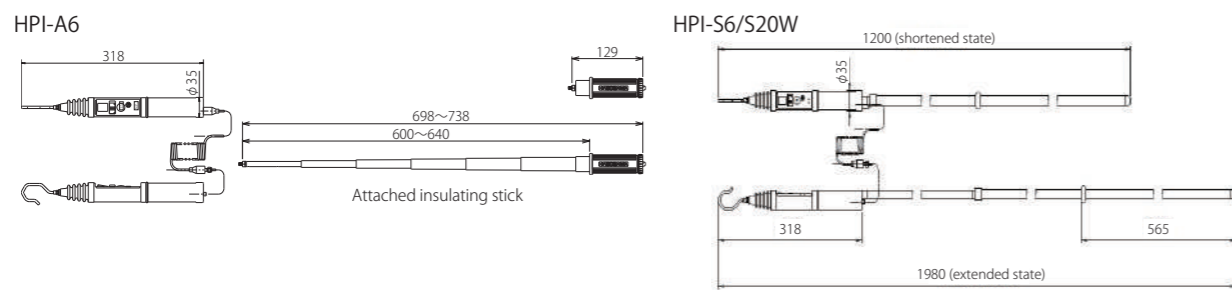

### Specifications

| Model                           | HPI-A6  | HPI-S6             | HPI-S20W     |
|---------------------------------|---|--------------------|--------------|
| Working voltage range           | AC 3kV~7kV  | AC 6.6kV           | AC 22kV~42kV |
| Target                          | For cubicles  | For overhead lines |              |
| Frequency                       | 50/60Hz   |                    |              |
| Insulation resistance           | 2000MΩ or more  |                    |              |
| Operating temperature range     | -10°C~+40°C   |                    |              |
| Indication of operation         | It shall be able to confirm luminance of 8,000 lux.   |                    |              |
| Phase test function             | 50 dB or more at a distance of 1 m from the sound-generating part (intermittent sound generation)   |                    |              |
| Phase sequence function         | Detection of in-phase or different phase of 120°  |                    |              |
| Possible distance of phase test | Detection of advance or delay of 120°   |                    |              |
| Battery                         | Distance between transmitter and receiver, with standard optical cable: 6 m (3m X 2)<br>It can be used at up to 30 m with the optional optical cable. |                    |              |
| Battery                         | R1(1.5V), each 2 pcs  |                    |              |

### Option

Optical fiber cable



- 10m (DF01066-1)
- 20m (DF01066-2)
- 30m (DF01066-3)

\* Use extended with a joint is not possible.

# HPR Series

High Voltage Phase Tester Wireless Type

AC 20kV~42kV

## Easy-to-use with Wireless Pair Renewed with phase sequence function

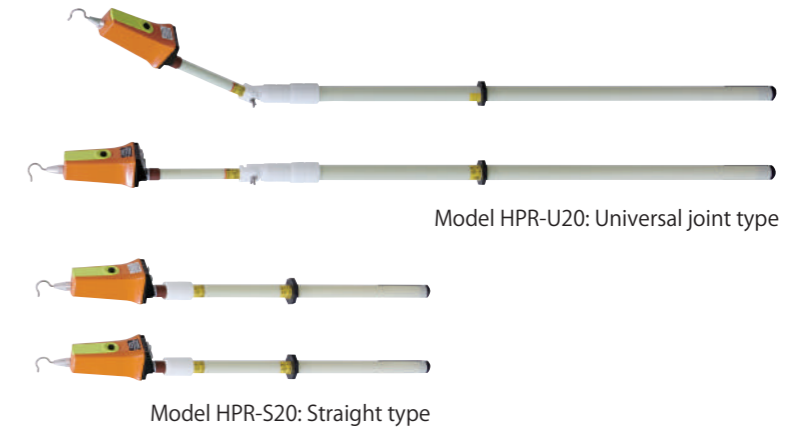

### Features

- When used alone, it becomes a power detection function, and when used in combination, it becomes a phase detection and phase
- \*Universal joint type

### Specifications

| Model                       | HPR-S20   | HPR-U20  |
|-----------------------------|---|--|
| Construction                | Straight type   | Universal joint type (for both horizontal and vertical arrangements) |
| Working voltage range       | AC 20kV~42kV  |  |
| Frequency                   | 50/60 Hz  |  |
| Phase test function         | Determines whether the phase of P2 is in phase with or different from P1 by 120°          |  |
| Distance for phase test     | Distance between P1 and P2: 5 m or less   |  |
| Overall length              | In a stretched state: 1,245 mm<br>In a shrunken state: 870 mm                             | 3,500 mm<br>1,670 mm   |
| Operation status display    | Light: Visible at a luminance of 8,000 lx<br>Sound: 50 dB or greater at a distance of 3 m |  |
| Batteries to use            | Two AAA batteries for P1 and P2 each (LR03 or R03)  |  |
| Operating temperature range | -10 to +40°C  |  |
| Water resistance            | Waterproof structure (IPX4 or equivalent)   |  |
| Weight                      | Approx. 900 g X 2   | Approx. 2,200 g X 2  |
| Accessories                 | Bag case  | Trunk case   |

| Dielectric strength   | AC 75 kV for 1 min | HPR-S20, HPR-U20 |
|---|--------------------|------------------|
| 30 cm intervals between creeping surface and creeping surface of insulating stick. (2 locations)<br>*Except for the antenna portion |                    |                  |

### Operation display

**Combination test** Press test button of P1 and P2 and check the operation

P1 : combination test → No sound emission center LED (yellow) lit

P2 : combination test → Light emission (red)

**In-phase** P1 does not emit sound and LED (center) is lit → Electric lines of P1 and P2 are in phase

P1: No sound or light emission (center) P2: Light emission (red)

**Phase sequence**

P1: Sound and light emission (green) P2: Light emission (red)

**Out of phase** P1 emits sound and light → Electric lines of P1 and P2 are out of phase

P1: Sound and light emission (green or red) P2: Light emission (red)

## HLA-1A

Voltage Detector Checker

### Handy Type with Built-in Battery



#### ■Features

- Easy to use at the site
- Checking low/high voltage is possible.
- Compact size and lightweight make it convenient to carry

#### ■Specifications

|                             |  |
|-----------------------------|--|
| Output voltage              | H terminal ----- 400 VAC ±20%<br>L terminal ----- 100 VAC ±20%             |
| Output frequency            | 55Hz ±10Hz   |
| Short-circuit current       | 0.5 mA or less   |
| Operating temperature range | -10°C ~ +50°C  |
| Battery                     | LR03(1.5V) × 4 pcs<br>Battery life ----- Total operating time: About 1 hr. |
| Dimensions                  | 65mm × 120mm × 40mm  |
| Weight                      | 430g   |

## HLA-2G

Voltage Detector Checker

### Handy Type with Built-in Battery



#### ■Features

- Ideal for checking voltage detectors for communication use

#### ■Specifications

|                             |  |
|-----------------------------|--|
| Output voltage              | H terminal ----- 1.2 kVAC ±20%<br>L terminal ----- 70 VAC ±20%                   |
| Output frequency            | 55Hz ±10%  |
| Short-circuit current       | 0.5 mA or less   |
| Operating temperature range | 0°C ~ +50°C  |
| Battery                     | 6R61 or 6F22(9V) × 2 pcs<br>Battery life ----- Total operating time: About 2 hr. |
| Dimensions                  | 80mm × 150mm × 50mm  |
| Weight                      | 700g   |

## HLA-N2

DC voltage Detector Checker

### Handy Type with Built-in Battery



#### ■Features

- Exclusive use for DC high voltage detector (Optimum for HS-1.5NR & HS-1.5NJ voltage detectors)

#### ■Specifications

|                             |                     |
|-----------------------------|---------------------|
| Output voltage              | DC1kV ±400V         |
| Load resistance             | 50 MΩ or more       |
| Short-circuit current       | 0.5 mA or less      |
| Operating temperature range | -10°C ~ +50°C       |
| Battery                     | LR03(1.5V) × 4 pcs  |
| Dimensions                  | 72mm × 114mm × 45mm |
| Weight                      | 280g                |

## HLA-3

Voltage Detector Checker

### Handy Type with Built-in Battery



#### ■Features

- Recommend for CL-1-06
- Handy type with built-in battery

#### ■仕様

|                             |  |
|-----------------------------|--|
| Output voltage              | 4kV AC ±15%  |
| Output lamp                 | Red LED (If the battery is low, turn off the lamp)   |
| Output frequency            | 55 Hz ±10 Hz   |
| External dimensions         | 100mm × 200mm × 70mm   |
| Short-circuit current       | 0.5 mA or lower  |
| Weight                      | About 1,200g (battery not included)  |
| Operating temperature range | 0°C to +50°C   |
| Built-in battery            | 9V (6LR61 or 6LF22) × 2 pcs<br>Life of the battery: cumulative operating hours of approx. 2 hours<br>*6F22 batteries are not usable. |

#### ■Corresponding table of detector checkers

| MODEL           | HLA-1A | HLA-2G | HLA-N2 | HLA-3 |
|-----------------|--------|--------|--------|-------|
| HTE-610W/WL     | ○      | ○      |        |       |
| HTE-700D/DL     | AC     | ○      |        |       |
|                 | DC     |        |        |       |
| HT-670          | AC     | ○      |        |       |
|                 | DC     |        |        |       |
| HSE-11          | ○      | ○      |        | ○     |
| HSE-7G          | ○      | ○      |        | ○     |
| HSS-25B1        | ○      | ○      |        | ○     |
| HSG-6           | ○      | ○      |        | ○     |
| HSN-6A2         | AC     | ○      |        | ○     |
|                 | DC     |        | ○      |       |
| HST-1.5N        | AC     | ○      |        | ○     |
|                 | DC     |        | ○      |       |
| HST-30W         |        |        |        | ○     |
| HST-20N         | AC     |        |        | ○     |
|                 | DC     |        |        | ○     |
| HST-30/30L      |        |        |        | ○     |
| HST-70/70L/W80L |        |        |        | ○     |
| HST-170         |        |        |        | ○     |
| HST-250         |        |        |        | ○     |
| HSR-90N         | AC     |        |        | ○     |
|                 | DC     |        |        |       |
| HSR-500         |        |        |        |       |

# HXG-1

Portable Live Part Detector

AC 3.3kV ~ 77kV



Determine whether the Substation Facilities are charged



Accessory



Storage case

### Specifications

|                             |   |
|-----------------------------|---|
| Working voltage range       | 3.3 kV to 77 kV   |
| Frequency                   | 50/60Hz   |
| Dielectric strength         | Between contact tip and grip: Extended state 20 kVAC, 1 min   |
| Detection performance       | Operation Voltage-Distance: 3.3kV - 0.2m<br>* Operation Voltage-Distance are theoretical value.     |
| Operation status display    | Light<br>Sound  |
|                             | Can be confirmed at the distance of 50 cm in the luminance of 8,000 lux.<br>50dB or more (1m apart) |
| Battery                     | LR44(1.5V) × 2 pcs  |
| Operating temperature range | -10°C ~ +40°C   |
| Weight                      | 85g   |

### Voltage & distance to be separated, and detectable distance

| Voltage (kV)            | 3.3 | 6.6 | 11  | 22  | 33  | 66  | 77  |
|-------------------------|-----|-----|-----|-----|-----|-----|-----|
| Detectable distance (m) | 0.2 | 0.5 | 1.0 | 1.7 | 2.2 | 2.9 | 3.0 |

Operation distance is varied depending on the actual surrounding environment. Please confirm operation distance in actual use environment before using.

# HXC-3K

Portable Live Part Detector

AC 3.3kV ~ 77kV



Determine whether the Substation Facilities are charged



### Features

- Compact size and lightweight make it convenient to carry

### Specifications

|                             |   |
|-----------------------------|---|
| Working voltage range       | 3.3 kV to 77 kV (Non-contact type for 11 kV or higher)  |
| Frequency                   | 50/60Hz   |
| Dielectric strength         | Between tip part and grip of detector 20 kVAC, 1 min (Leakage current: 1 mA or less)                |
| Detection performance       | Operation starting voltage: 400 V ± 20%<br>Detectable distance: 5 cm at 3.3 kV, 10 cm at 6.6 kV     |
| Operation status display    | Light<br>Sound  |
|                             | Can be confirmed at the distance of 50 cm in the luminance of 8,000 lux.<br>50dB or more (1m apart) |
| Dimensions                  | 155mm   |
| Battery                     | LR44(1.5V) × 2 pcs  |
| Operating temperature range | -20°C ~ +40°C   |
| Weight                      | 35g   |

\* Without the casing

### Voltage & distance to be separated, and detectable distance

| Voltage (kV)                            | 3.3 | 6.6 | 11 | 22 | 33  | 77  |
|---|-----|-----|----|----|-----|-----|
| Necessary distance to be separated (cm) | —   | —   | 15 | 25 | 35  | 76  |
| Detectable distance (cm)                | 5   | 10  | 33 | 90 | 120 | 230 |

# Hot Line Proximity Alarm

Auxiliary voltage detection device that gives alarm sounding at a distance when approach to a live line.

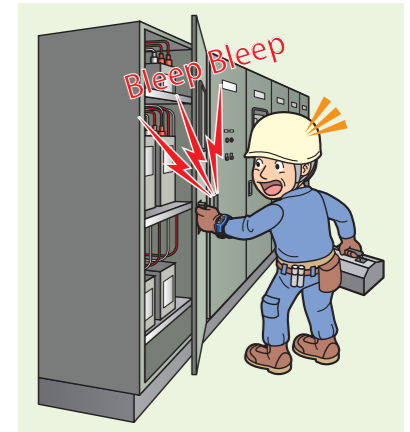
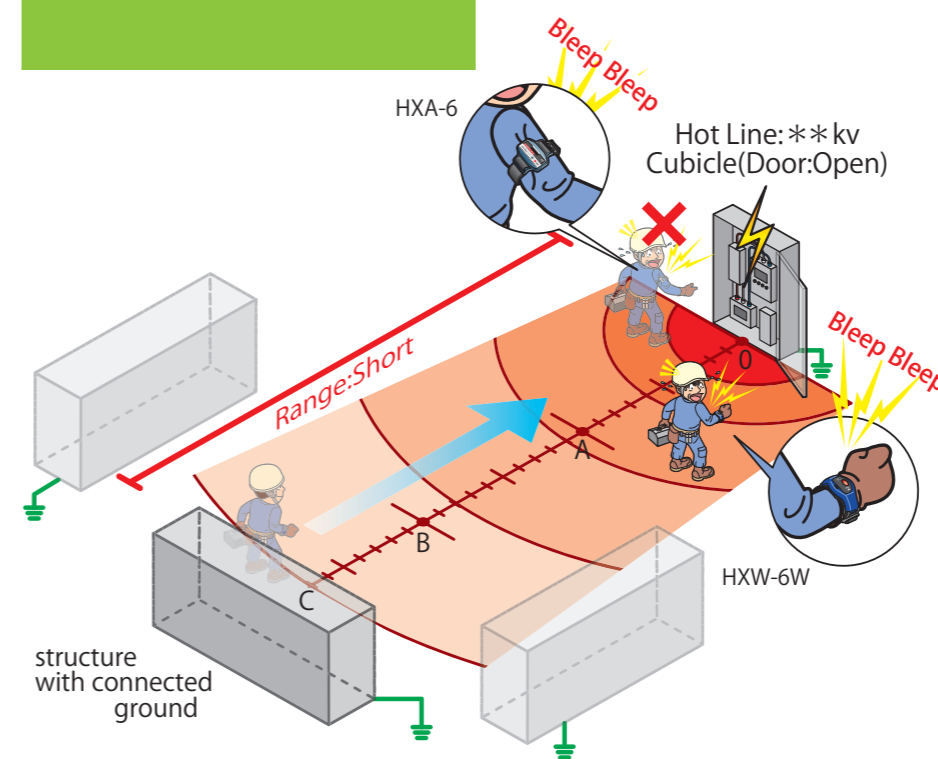

## Hot Line Proximity Alarm

### What is a Hot line proximity alarm?

- It is a product that generates an alarm when it detects a voltage at a distance to prevent accident of electric shock. Unintended access due to human errors such as preconception or misconception can be prevented.
- This product cannot be used as a voltage detector.

### Precautions before purchasing the Hot line proximity alarm

- Please use proper model according to the applications, because detection sensitivity has been adjusted for cubicle works and overhead line works respectively assuming the general site conditions.
- The specification "○V-○cm" of this product is a distance under the "standard condition" set in the factory. At actual sites, the operation distance may become shorter, depending on environment, wiring conditions, etc. (\*1) (\*1) e.g.: When a grounded structure exists nearby, etc.
- The sensitivity of this product is directional. Sensitivity is reduced at the back of the product (in the case of HXW-6W, direction of the palm).

#### Image of operating distance

Detection is easier in the direction of fingertips and lateral direction.

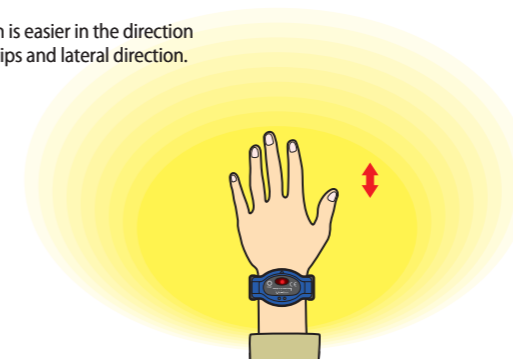

In the direction of the palm, the detecting distance is shorter than in the upper direction.

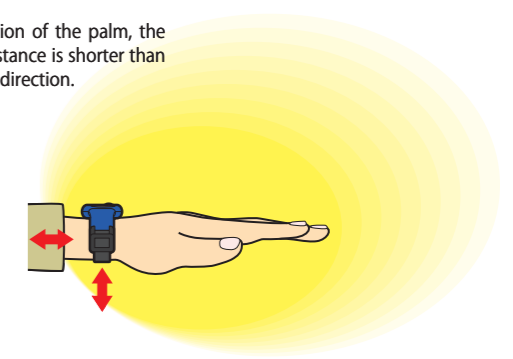

# HXW-6WL

WRIST ALARM

AC 400V to 22kV



Applicable from low voltage to high voltage



\* Rubber band is attached to the product.

Option



Silicone band

### Specifications

|                                 |   |
|---------------------------------|---|
| Model                           | HXW-6WL   |
| Working Voltage range           | 400V to 22kV  |
| Standard distance for operation | 25cm against 400V (230V to ground)<br>* Under Hasegawa's standard conditions. |
| Frequency                       | Both 50Hz and 60Hz  |
| Sound volume                    | 65dB or more (60cm apart)   |
| Battery                         | Coin type Lithium battery (CR1620) 1 piece                                    |
| Operating temperature range     | -10°C ~ +40°C   |
| Dimensions                      | (W) 77mm × (D) 40mm × (T) 14mm  |
| Weight                          | About 35g   |

### Operation Voltage Distance graph (Theoretical value)

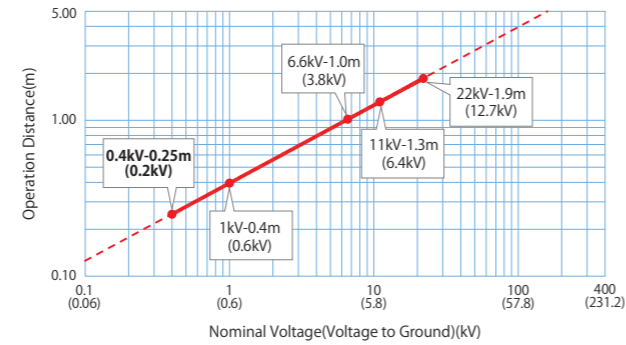

### Operation Voltage Distance Table (Theoretical value)

| Normal Voltage | Operation Distance |
|----------------|--------------------|
| 0.4kV          | 0.25m              |
| 1kV            | 0.4m               |
| 6.6kV          | 1.0m               |
| 11kV           | 1.3m               |
| 22kV           | 1.9m               |

Operation Voltage-Distance Table and graph are theoretical value. Operation distance is varied depending on the actual surrounding environment. Please confirm operation distance in actual use environment before using.  
\* When used with overhead distribution lines, the operating distance will be longer.  
\* HXW-6WL is the customized model which is specialized in detecting low voltage. It may begin to operate at longer distance than necessary when using in the field of Mid-High voltage. If it may begin to operate at longer distance than necessary, consider using theoretical model.

# HXW-6W

(Both 50Hz and 60Hz)

WRIST ALARM

AC 1kV to 42kV



Exclusively for cubicle works



\* Rubber band is attached to the product.

Option



Silicone band

### Specifications

|  |   |
|--|---|
| Model  | HXW-6W  |
| Working Voltage range                              | 1kV to 42kV   |
| Alarm starting distance (Under standard condition) | 60cm against 6.6kV (3.8kV to ground)  |
| Frequency  | Both 50Hz and 60Hz  |
| Sound volume                                       | 65dB or more (60cm apart)   |
| Battery  | CR1620 (3V) × 1pcs  |
| Battery life (with new battery)                    | Continuously operating state: About 15 hr.<br>Unused state: About 10 months |
| Operating temperature range                        | -10°C ~ +40°C   |
| Weight   | About 35g   |

### Operation Voltage Distance graph (Theoretical value)

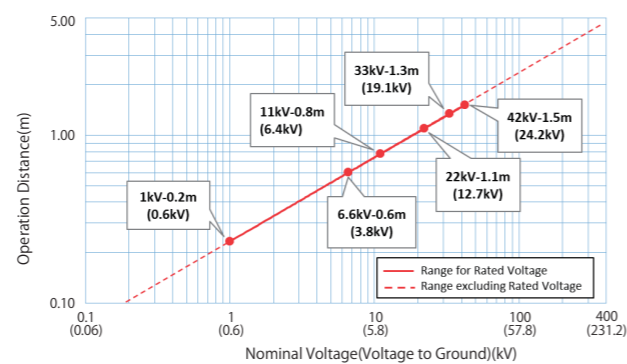

### Operation Voltage Distance Table (Theoretical value)

| Normal Voltage | Operation Distance |
|----------------|--------------------|
| 6.6kV          | 0.6m               |
| 11kV           | 0.8m               |
| 22kV           | 1.1m               |
| 33kV           | 1.3m               |

Operation Voltage-distance table and graph are theoretical value. Operation distance is varied depending on the actual surrounding environment. Please confirm operation distance in actual use environment before using.

# Hot Line Proximity Alarm

Auxiliary voltage detection device that gives alarm sounding at a distance when approach to a live line.

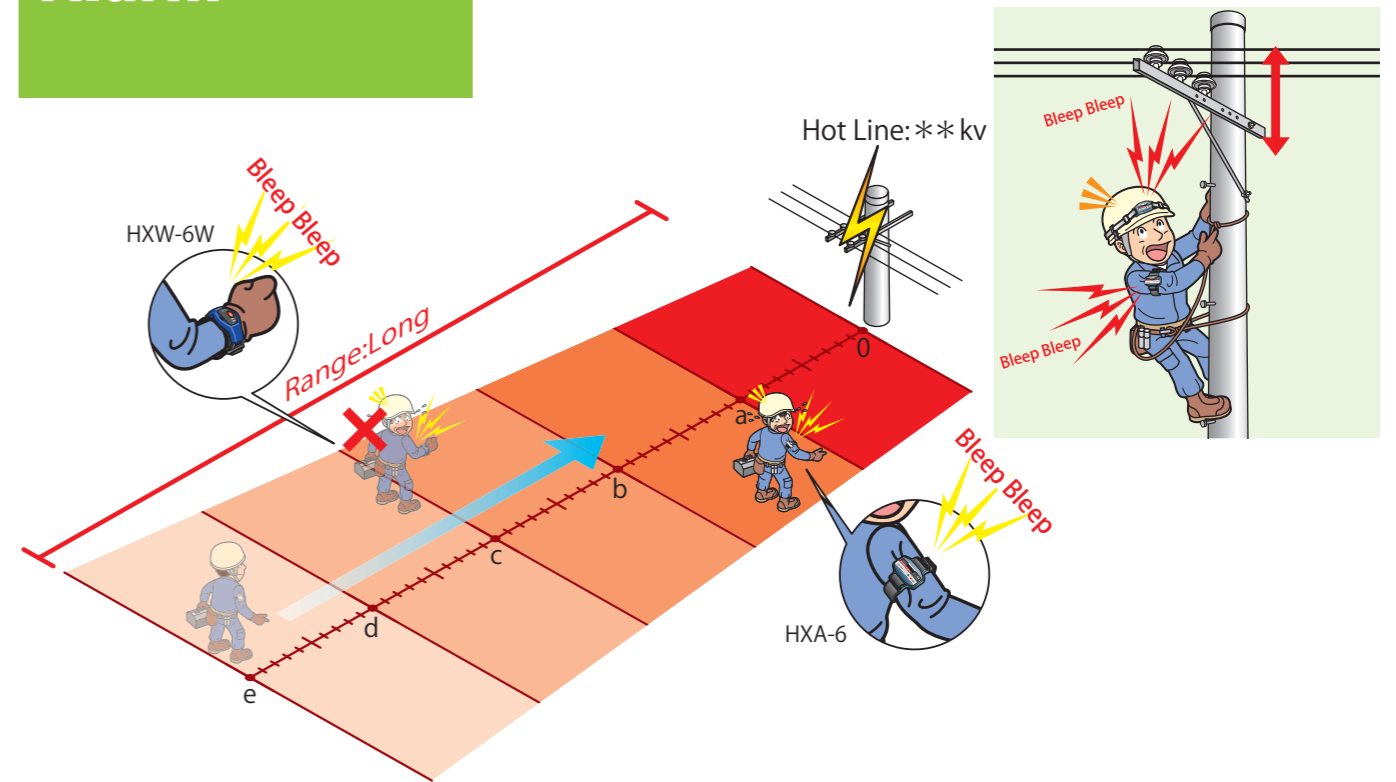

# HXA-6 HXA-6S

AC 6.6kV to 33kV



Hot line proximity detector exclusively for overhead line works

**[Attention]**  
This is not suitable for cubicle works.

### Specifications

| Model  | HXA-6  | HXA-6S                        |
|--|--|-------------------------------|
| Location of use                                    | Exclusive for work with overhead lines         |                               |
| Alarm starting distance (Under standard condition) | 80cm   | 110cm                         |
| Frequency  | Either 50 Hz or 60 Hz, whichever is designated |                               |
| Sound volume                                       | 65dB or more (1m apart)                        |                               |
| Battery  | JIS CR2032(3V) × 1 pcs                         |                               |
| Battery life (with new battery)                    | Continuously operating state: About 15 hr.     | Unused state: About 10 months |
| Operating temperature range                        | -10°C ~ +40°C                                  |                               |
| Weight   | About 45 g (body only)                         |                               |
| External dimensions                                | (W) 78 × (D) 82 × (T) 25                       | (W) 94 × (D) 48 × (T) 27.5    |
| Accessories  | Fixing band                                    | Fixing band, Holder (2pcs)    |

HXA-6 (Upper arm fitting type) HXA-6S (Helmet fitting type)



### Operation Voltage Distance graph (Theoretical value)

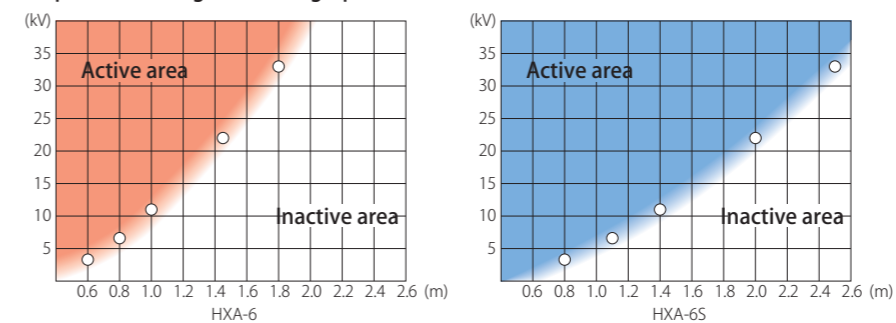

### Operation Voltage Distance Table (Theoretical value)

| Normal Voltage | Operation Distance |       |
|----------------|--------------------|-------|
|                | HX-6               | HX-6S |
| 6.6kV          | 0.8m               | 1.1m  |
| 11kV           | 1.0m               | 1.4m  |
| 22kV           | 1.5m               | 2.0m  |
| 33kV           | 1.8m               | 2.5m  |

Operation Voltage-distance table and graph are theoretical value. Operation distance is varied depending on the actual surrounding environment. Please confirm operation distance in actual use environment before using.

# HXA-30 HXA-30S

## Hot line proximity detector exclusively for overhead line works

\* Please designate the frequency (50 Hz or 60 Hz).

**[Attention]**  
This is not suitable for cubicle works.

AC 11kV to 66kV



HXA-30 (Upper arm fitting type)

HXA-30S (Helmet fitting type)



### Specifications

| Model                             | HXA-30   | HXA-30S  |
|-----------------------------------|--|--|
| Standard operation start distance | 11kV (Voltage to ground: 6.4 kV) - 70 cm (under normal conditions) | 11 kV (Voltage to ground: 6.4 kV) - 100 cm (under normal conditions) |
| Frequency                         | 50 Hz / 60 Hz  |  |
| Sound volume                      | 65 dB or more  |  |
| Battery for use                   | JIS CR2032 (3V) x 1  |  |
| Allowable temperature range       | -10°C to +40°C (with no surface or internal condensation)          |  |
| Weight                            | About 45 g (body only)   |  |
| External dimensions               | (W) 78 × (D) 82 × (T) 25   | (W) 94 × (D) 48 × (T) 27.5   |
| Accessories                       | Fixing band  | Fixing band, Holder (2pcs)   |

### Operation Voltage Distance graph (Theoretical value)

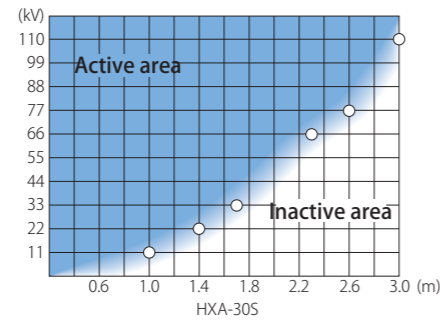
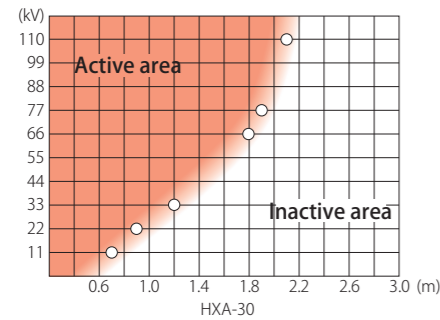

### Operation Voltage Distance Table (Theoretical value)

| Normal Voltage | Operation Distance |         |
|----------------|--------------------|---------|
|                | HXA-30             | HXA-30S |
| 11kV           | 0.7m               | 1.0m    |
| 22kV           | 0.9m               | 1.4m    |
| 33kV           | 1.2m               | 1.7m    |

Operation Voltage-distance table and graph are theoretical value.  
Operation distance is varied depending on the actual surrounding environment.  
Please confirm operation distance in actual use environment before using.

# HXA-70 HXA-70S

## Hot line proximity detector exclusively for overhead line works

\* Please designate the frequency (50 Hz or 60 Hz).

**[Attention]**  
This is not suitable for cubicle works.

AC 66kV to 110kV



HXA-70 (Upper arm fitting type)

HXA-70S (Helmet fitting type)



### Specifications

| Model                             | HXA-70  | HXA-70S   |
|-----------------------------------|---|---|
| Standard operation start distance | 66 kV (Voltage to ground: 38 kV) - 150 cm (under normal conditions) | 66 kV (Voltage to ground: 38 kV) - 150 cm (under normal conditions) |
| Frequency                         | 50 Hz / 60 Hz   |   |
| Sound volume                      | 65 dB or more   |   |
| Battery for use                   | JIS CR2032 (3V) x 1   |   |
| Allowable temperature range       | -10°C to +40°C (with no surface or internal condensation)           |   |
| Weight                            | About 45 g (body only)  |   |
| External dimensions               | (W) 78 × (D) 82 × (T) 25  | (W) 94 × (D) 48 × (T) 27.5  |
| Accessories                       | Fixing band   | Fixing band, Holder (2pcs)  |

### Operation Voltage Distance graph (Theoretical value)

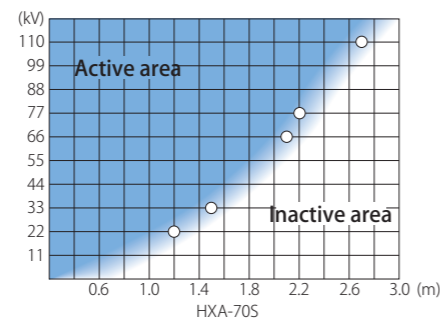
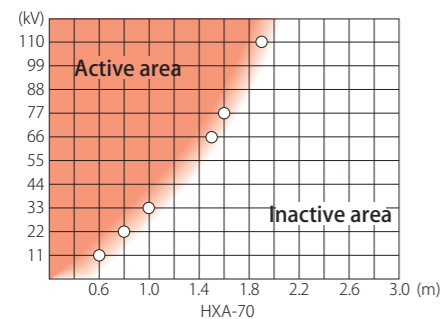

### Operation Voltage Distance Table (Theoretical value)

| Normal Voltage | Operation Distance |         |
|----------------|--------------------|---------|
|                | HXA-70             | HXA-70S |
| 66kV           | 1.5m               | 2.1m    |
| 77kV           | 1.6m               | 2.2m    |
| 110kV          | 1.9m               | 2.7m    |

Operation Voltage-distance table and graph are theoretical value.  
Operation distance is varied depending on the actual surrounding environment.  
Please confirm operation distance in actual use environment before using.

# Railway Products

■ Railway Products ..... P.41

■ Measuring Instrument ..... P.47

# HVC-1.5N3

Voltage Detector for DC Overhead Contact Wire

DC 750V~2kV



### ■ Features

- Light weight body [About half weight compared with previous product.]
- Promote the checking before detect the voltage.
- Memorize the setting of volume control.
- Simplified the checking before detect the voltage.
- Adopt a strong Grounding magnet.
- Large Indication.

## Voltage Detector for DC 1500V Contact Wires, Visualization of decreasing Residual Voltage

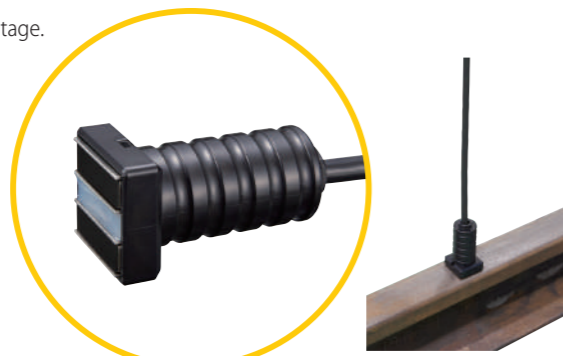
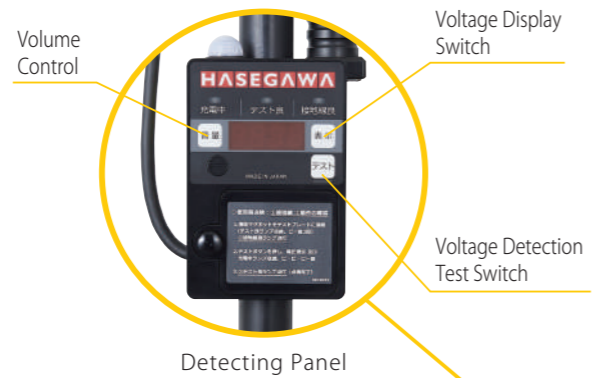

Grounding Magnet



### ■ Dimensions

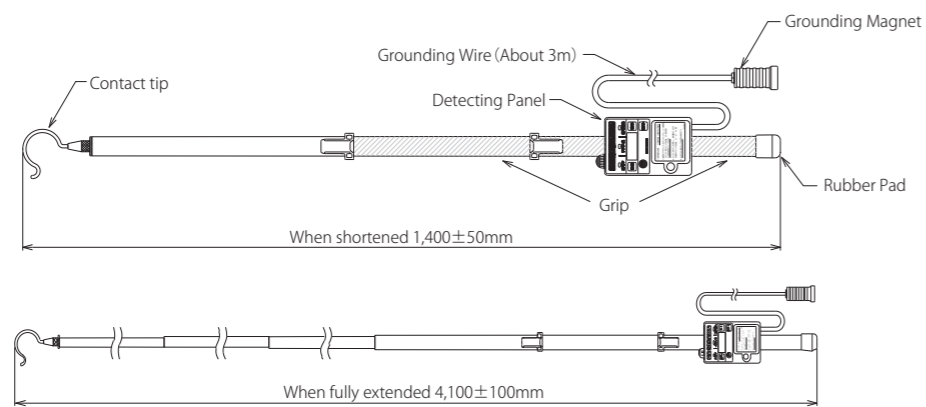

### ■ Specifications

|  |  |
|--|--|
| Working voltage range                          | DC 750V~2kV (Bare conductors)<br>* Voltage detection of negative potential is not possible.  |
| Operation starting voltage (Voltage to ground) | DC750V ± 50V   |
| Display  | Operation display (charging)<br>Check of earth wire (Earth wire is OK)   |
|  | Red LED and buzzer<br>Green LED  |
| Voltage display                                | Range: 0 VDC to 1999 VDC Resolution: 1 V, Accuracy within ±5%±5V   |
| Volume adjustment for buzzer sound             | Each time when the sound volume push-button switch is pressed, the cycle of High → Medium → Low → High ----- is repeated. Sound volume at a distance of 1 m<br>High: 75 dB or more Medium: 60 to 75 dB, Low: 60 dB or less |
| Output voltage at test                         | DC1000V ± 200V   |
| Dielectric strength                            | Contact tip (Metal fitting) – Grounded part 4 kVAC, 1 min  |
| Leakage current                                | 1 mA or less at dielectric strength test   |
| Battery  | R6 or LR6(1.5V) × 4 pcs  |
| Operating temperature range                    | 0°C ~ +50°C  |
| Weight   | About 2.3kg  |

### ■ Accessory



Bag for housing

# HVC-750N3

Voltage Detector for DC Third Rail

DC 300V~2kV



### ■ Features

- Promote the checking before detect the voltage.
- Memorize the setting of volume control.
- Simplified the checking before detect the voltage.
- Adopt a strong Grounding magnet.

## Voltage Detector for DC 750V Contact Wires, Visualization of decreasing Residual Voltage



Grounding Magnet



### ■ Dimensions

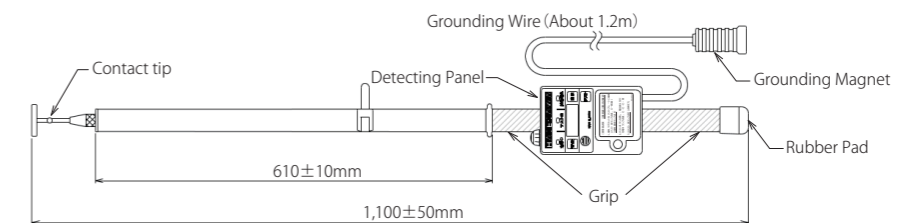

### ■ Specifications

|  |  |
|--|--|
| Working voltage range                          | DC300V~2kV (Bare conductors)<br>* Voltage detection of negative potential is not possible.   |
| Operation starting voltage (Voltage to ground) | DC300V ± 20V   |
| Display  | Operation display (charging)<br>Check of earth wire (Earth wire is OK)   |
|  | Red LED and buzzer<br>Green LED  |
| Voltage display                                | Range: 0 VDC to 1999 VDC Resolution: 1 V, Accuracy within ±5%±5V   |
| Volume adjustment for buzzer sound             | Each time when the sound volume push-button switch is pressed, the cycle of High → Medium → Low → High ----- is repeated. Sound volume at a distance of 1 m<br>High: 75 dB or more Medium: 60 to 75 dB, Low: 60 dB or less |
| Output voltage at test                         | DC500V ± 100V  |
| Dielectric strength                            | Contact tip (Metal fitting) – Grounded part 4 kVAC, 1 min  |
| Leakage current                                | 1 mA or less at dielectric strength test   |
| Battery  | R6 or LR6(1.5V) × 4 pcs  |
| Operating temperature range                    | 0°C ~ +50°C  |
| Weight   | About 1.4kg  |

### ■ Accessory



Bag for housing

# HVC-1.5N3S

Voltage Detector for DC Substation

DC 750V~2kV



**HVC-1.5N3S**  
The plate is attached to grounding clip Inspection before use



It can be grounded in various place;etc cubicle Please use two clips at the same time.

### Dimensions

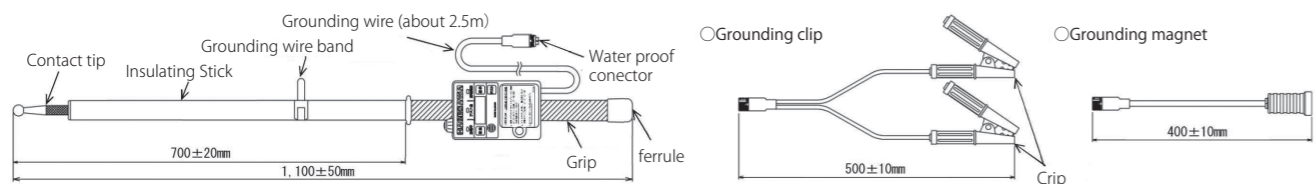

# Voltage detector for DC 1500V substation



Accessory  
直流検電器 DC Voltage Detector  
Bag for housing

### Option



**HVC-1.5N3S** Grounding magnet (UH20004)  
**HVC-1.5N3S** Grounding clip (UH20003)  
**HVC-1.5N3S** The plate is attached to grounding clip Inspection before use (DH18007)

# HVC-1.5N3M

Voltage Detector for Monorail

DC 300V~2kV

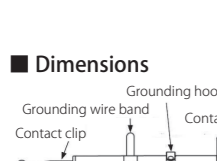

**HVC-1.5N3M**  
The plate is attached to grounding clip Inspection before use

# Voltage detector for monorail



Accessory  
直流検電器 DC Voltage Detector  
Bag for housing

### Option



**HVC-1.5N3M** Grounding magnet (UH20004)  
**HVC-1.5N3M** Grounding clip (UH20003)  
**HVC-1.5N3M** The plate is attached to grounding clip Inspection before use (DH18007)

### Dimensions

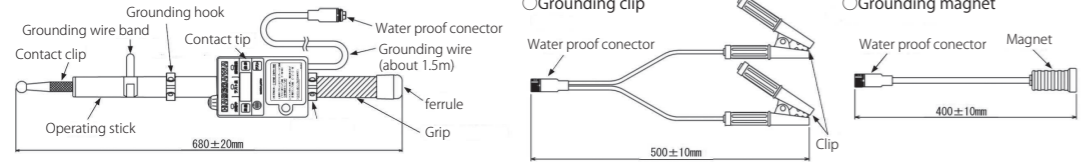

### Specifications

| Model  | HVC-1.5N3S  | HVC-1.5N3M                       |
|--|---|----------------------------------|
| Working voltage                                | DC750V~2kV  | DC300V~2kV                       |
|  | Max DC2kV (in contact with bare wire) *Voltage detection of negative potential is not possible. |                                  |
| Operation strating voltage (Voltage to ground) | DC750V±50V  | DC300V±20V                       |
| Insulation resistance                          | contact tip-grounding clip 10MΩ±10%(with 1,000Vmega measuring instrument)                       |                                  |
| Dielectric strength                            | contact tip-grounding magnet AC4,000V,1 min   |                                  |
| Leakage current                                | 1 mA or less at dielectric strenght test  |                                  |
| Operating temperature range                    | 0°C~+50°C   |                                  |
| Volume adjustment for buzzer sound             | Sound volume at a distance of 1m  |                                  |
| Output voltage at test                         | DC1,000V±200V   | DC500V±100V                      |
| Battery  | R6 or LR6(1.5V) x 4 pcs   |                                  |
| Structure                                      | Dustproof,Waterproof(Equivalent toIP44)   |                                  |
| Weight   | About 1.8kg(with grounding clip)  | About 1.6kg(with grounding clip) |

# HSR-1.5NJ HSR-1.5NR

Medium Voltage Detector

AC 6.6kV  
DC HSR-1.5NJ: 600V~7kV  
HSR-1.5NR: 1kV~7kV

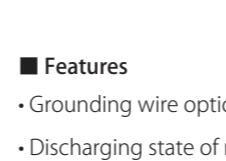

**HSR-1.5NJ**

# Voltage Detector of Dual Use for DC Contact Wire and AC 7kV

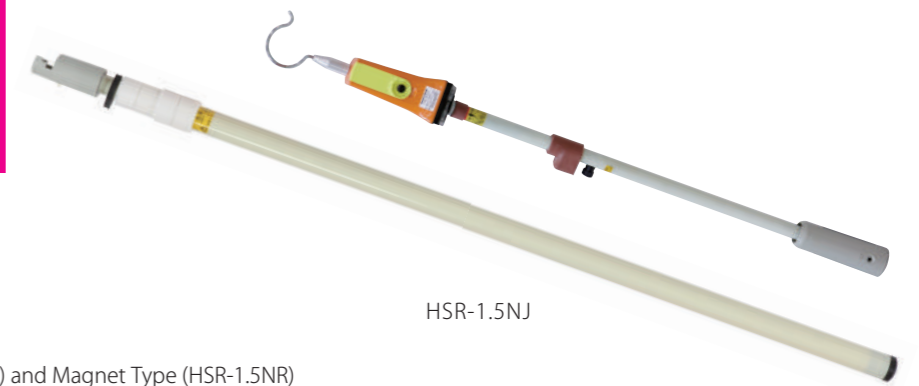

HSR-1.5NJ



HSR-1.5NR

### Features

- Grounding wire options : Clip Type (HSR-1.5NJ) and Magnet Type (HSR-1.5NR)
- Discharging state of residual charge after power outage can be distinguished (HSR - 1.5 NR)

### Operation display (HSR-1.5NR)

| Voltage  | Green LED |          | Red LED and buzzer |                  |
|--|-----------|----------|--------------------|------------------|
|  | Lighting  | Flashing | Lighting           | Sound generation |
| DC   | ○         | —        | ○                  | —                |
| AC   | —         | ○        | —                  | —                |
| After test and after voltage detection (not charged) | ○         | —        | —                  | —                |
| Approx. 350 to Approx. 750 V                         | —         | ○        | —                  | —                |
| Approx. 750 V or more                                | —         | —        | ○                  | —                |
| Approx. 1,000 to Approx. 2,000 V                     | —         | —        | —                  | ○                |
| Approx. 2,000 V or more                              | —         | —        | —                  | ○                |

- When the green LED is flashing, a residual electric charge within the range of working voltages is being discharged.
  - A stand-by display function is provided. When the test button is pressed, the green LED lights for about 30 sec.
- : Operation  
— : No operation

### Dimensions

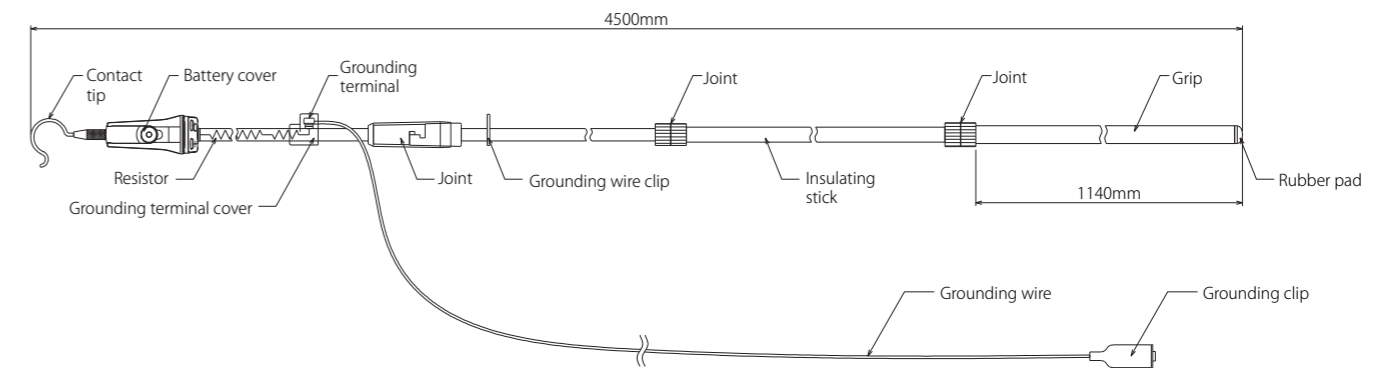

### Accessory



### Specifications

| Model  | HSR-1.5NJ   | HSR-1.5NJ1  | HSR-1.5NR   |
|--|---|-------------|---|
| Working voltage range                          | AC 6.6kV  | DC 600V~7kV |   |
|  | DC 1kV~7kV  |             |   |
| Operation starting voltage (Voltage to ground) | AC 2000V±20%  | DC 400V±20% |   |
|  | DC 800V±100V  |             | DC 750±100 V (Red LED)<br>350±80 V (Green LED flashes.) |
| Frequency                                      | 50/60Hz   |             |   |
| Grounding system                               | Clip  |             | Magnet  |
| Indication of operation                        | Light: It can be confirmed in the luminance of 8,000 lux.                     |             |   |
|  | Sound: Intermittent sound   |             | Continuous sound  |
| Battery  | 2 AAA batteries   |             |   |
| Accessory                                      | Clip type grounding wire (7 m)  |             | Magnet type grounding wire (7 m)                        |
|  | Bag for housing   |             |   |
| Weight   | About 3.2 kg  |             |   |
| Dielectric strength                            | Between contact tip (metal fitting) and grounding terminal: 14,000 VAC, 1 min |             |   |

# HST-W80JS

Voltage Detector for AC Overhead Contact Wire

AC 20kV~80.5kV



### Features

- Standby display function is provided.
- After pressing the test button, the green LED lights up even after voltage detection.
- \* The green LED automatically turns off in 1 to 2 min.
- Voltage detection is possible even after turning off (in case there is no problem with battery level)



Charged indication (Red LED lit) / Uncharged indication (Green LED lit)

### Dimensions

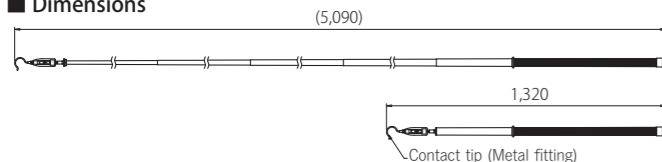

## Voltage Detector for AC Overhead Contact wires of normal Railways and Shinkansen



### Accessory



Bag for housing

### Specifications

|  |  |  |
|--|--|--|
| Working voltage range                          | AC20kV~80.5kV  |  |
| Operation starting voltage (Voltage to ground) | 5 kV ± 20% (bare wire)   |  |
| Frequency                                      | 50Hz/60Hz  |  |
| Indication of operation                        | Light  | It can be confirmed in the luminance of 8,000 lux. |
|  | Sound  | 50 dB or more at a distance of 2 m                 |
| Dielectric strength                            | Insulating stick, AC 75 kV/300mm x 1 min. (6 locations on the insulating stick, except for electrode and joints) |  |
| Leakage current                                | 100 μA or less at dielectric strength test/1 location  |  |
| Battery  | LR44(1.5V) × 2 pcs   |  |
| Battery life                                   | About 4 hr. continuous operation   |  |
| Operating temperature range                    | -10°C to +50°C (However, there shall be no dew condensation inside.)   |  |
| Weight   | About 1 kg   |  |

\* HST-W80JS-Y1 (spec. with Y-type Contact tip (Metal fitting)) also exists.

# Grounding Hook for Railways

Custom production is possible with combination of tip metal fitting, length of operating rod, length and size of earth wire, and grounding metal fitting.

### Tip metal fitting

| External appearance | Model name                        | Range of use (mm) | Dimension | Weight |
|---------------------|-----------------------------------|-------------------|-----------|--------|
|                     | SA106-A<br>Insertion type         | φ10~25            |           | 630g   |
|                     | SA106-C<br>Slanted insertion type | φ10~25            |           | 720g   |
|                     | SA106-S<br>Compact insertion type | φ4~10             |           | 400g   |

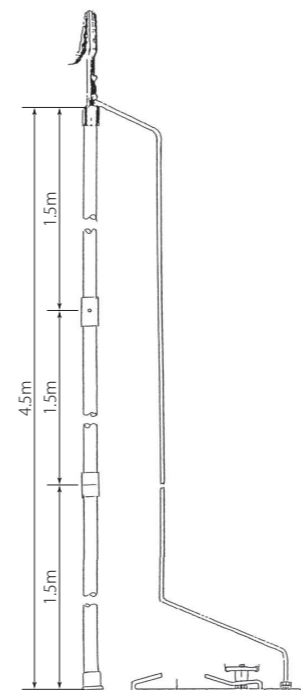

### Operating stick

| Type    | Length | Type      | Length | Number of connections                        |
|---------|--------|-----------|--------|--|
| Type 5  | 0.5m   | Type 35   | 3.5m   | Connection of 2 rods (1.5 m + 2.0 m)         |
| Type 10 | 1.0m   | Type 40   | 4.0m   | Connection of 2 rods (2.0 m + 2.0 m)         |
| Type 15 | 1.5m   | Type 45-A | 4.5m   | Connection of 2 rods (2.0 m + 2.5 m)         |
| Type 20 | 2.0m   | Type 45-B | 4.5m   | Connection of 3 rods (1.5 m + 1.5 m + 1.5 m) |
| Type 25 | 2.5m   | Type 50   | 5.0m   | Connection of 2 rods (2.5 m + 2.5 m)         |
| Type 30 | 3.0m   | Type 60-A | 6.0m   | Connection of 2 rods (3.0 m + 3.0 m)         |
|         |        | Type 60-B | 6.0m   | Connection of 3 rods (2.0 m + 2.0 m + 2.0 m) |

### grounding wire

| Cross-sectional area      | 38mm <sup>2</sup> | 60mm <sup>2</sup> | 100mm <sup>2</sup> |
|---------------------------|-------------------|-------------------|--------------------|
| Wire configuration        | 19/38/0.26        | 19/60/0.26        | 37/51/0.26         |
| Mass                      | 455g/m            | 680g/m            | 1120g/m            |
| Finished outside diameter | 12.9mm            | 15.2mm            | 19.0mm             |

### Standard model

| Type             | Tip metal fitting | Grounding wire        | Operating rod                                       | Grounding metal fitting | Bag for housing |
|------------------|-------------------|-----------------------|---|-------------------------|-----------------|
| SA106A Type 45-A | SA106A            | 60mm <sup>2</sup> ×7m | 4.5 m, connection of 2 rods (2.0 m + 2.5 m)         | SA120                   | Sold separately |
| SA106A Type 45-B | SA106A            | 60mm <sup>2</sup> ×7m | 4.5 m, connection of 3 rods (1.5 m + 1.5 m + 1.5 m) | SA120                   | Sold separately |

### Grounding metal fitting (SA120)

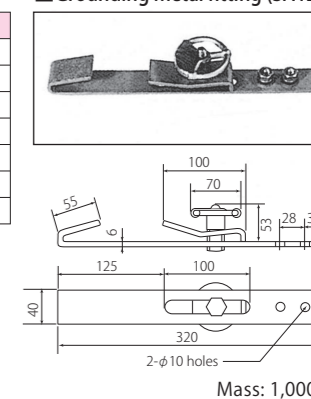

# HXR-20J (For normal railways) HXR-25J (For high speed rail)

Medium Voltage Hot-line Proximity Alarm

AC HXR-20J 20kV  
HXR-25J 25kV

### Features

- Alarm is generated at a distance of about 2 m from the energized overhead contact lines, normal railways (AC 20kV) and High Speed Railway (AC 25kV).
- It has directionality to identify overhead contact lines in a charged state.
- It is compact, lightweight, and can be fitted to a helmet with a one-touch operation

### Dimensions (common to Model HXR-20J & Model HXR-25J)

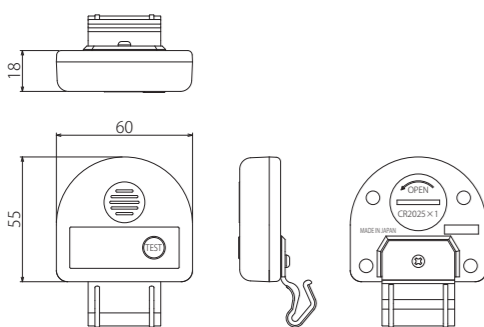

### Specifications

|  |   |
|--|---|
| Operating sensitivity (Electric field intensity) | HXR-20J : AC20kV<br>HXR-25J : AC25kV                |
| Standard operation starting distance             | About 2 m (It differs depending on the environment) |
| Sound volume                                     | 80dB/10cm or more                                   |
| Frequency  | 50/60 Hz  |
| Operating temperature range                      | -10°C~+40°C   |
| Battery  | CR2025(3V) x 1 pcs                                  |
| Battery life                                     | About two years in unused state                     |
| Dimensions                                       | 60mm×55mm×18mm                                      |
| Weight   | About 40g   |

## Non-contact Detection of Charging State of AC Overhead Contact Lines

Jointly developed with JR EAST (East Japan Railway Company)

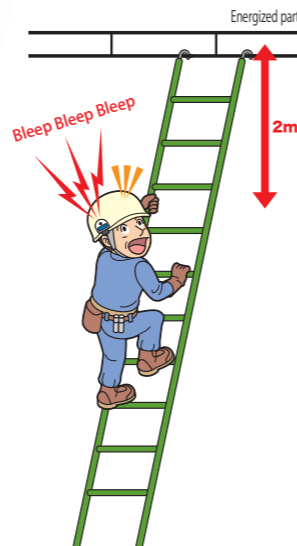

# Type R

DC 1.5kV

### Features

- No sagging of the ground wire because the operating rod and conductor are integrated.
- Grounding hardware can be securely fastened without passing under the rail.

### Dimensions

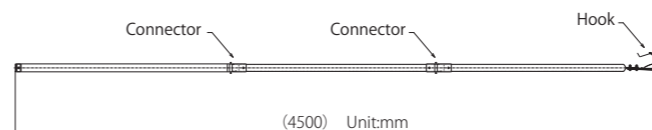

## Grounding hook for DC train lines

### Grounding metal fitting

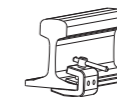

### Connection

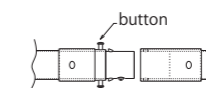

### Metal head fitting

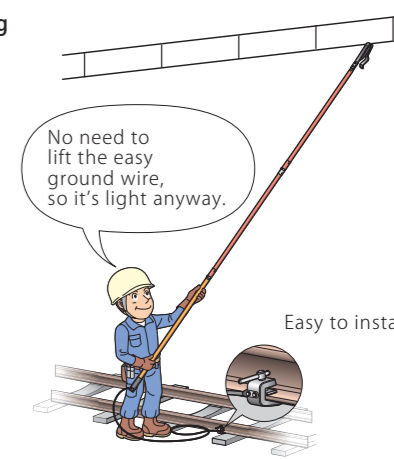
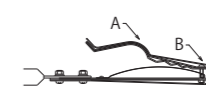

### Specifications

| Type                               | R  |
|------------------------------------|--|
| Target voltage range               | Less than DC1.5kV  |
| Grounding wire                     | transparent coated vinyl wire 60mm <sup>2</sup> —3m                    |
| Energizing performance             | 4000A AC/Within 0.2 seconds  |
| Hook attachable range              | A:φ60, B:φ15~φ25(unit:mm)  |
| Grounding bracket attachable range | 15~25(unit:mm)   |
| Dielectric strength                | Between surface of FPR and ground wire connection 5400V AC for 1minute |
| Weight                             | About 10.2kg   |

# VOLTECT

Extra-High Voltage  
Detecting System

AC 3.3kV~550kV

This indication and warning apparatus detects the presence or absence of a charged state of special high voltage substations, electric power transmission lines, power receiving equipment, etc. in a non-contact operation.

\* This apparatus is produced and sold by our company, having inherited inheriting technologies of former Million Electric Mfg. Co. Ltd.

### Features

- Economical as it can be simply installed without using PT, PD.
- Easy installation and maintenance.

### Protector

- HG7-P1B (for single phase)
- HG7-P2B (for two-phase)



### Controller

- HG7-SM○○
  - HG7-DM○○
- \* Refer to the following Rating table.

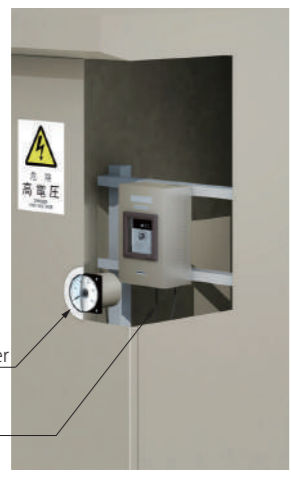

### Voltage Meter

- DVF-11M

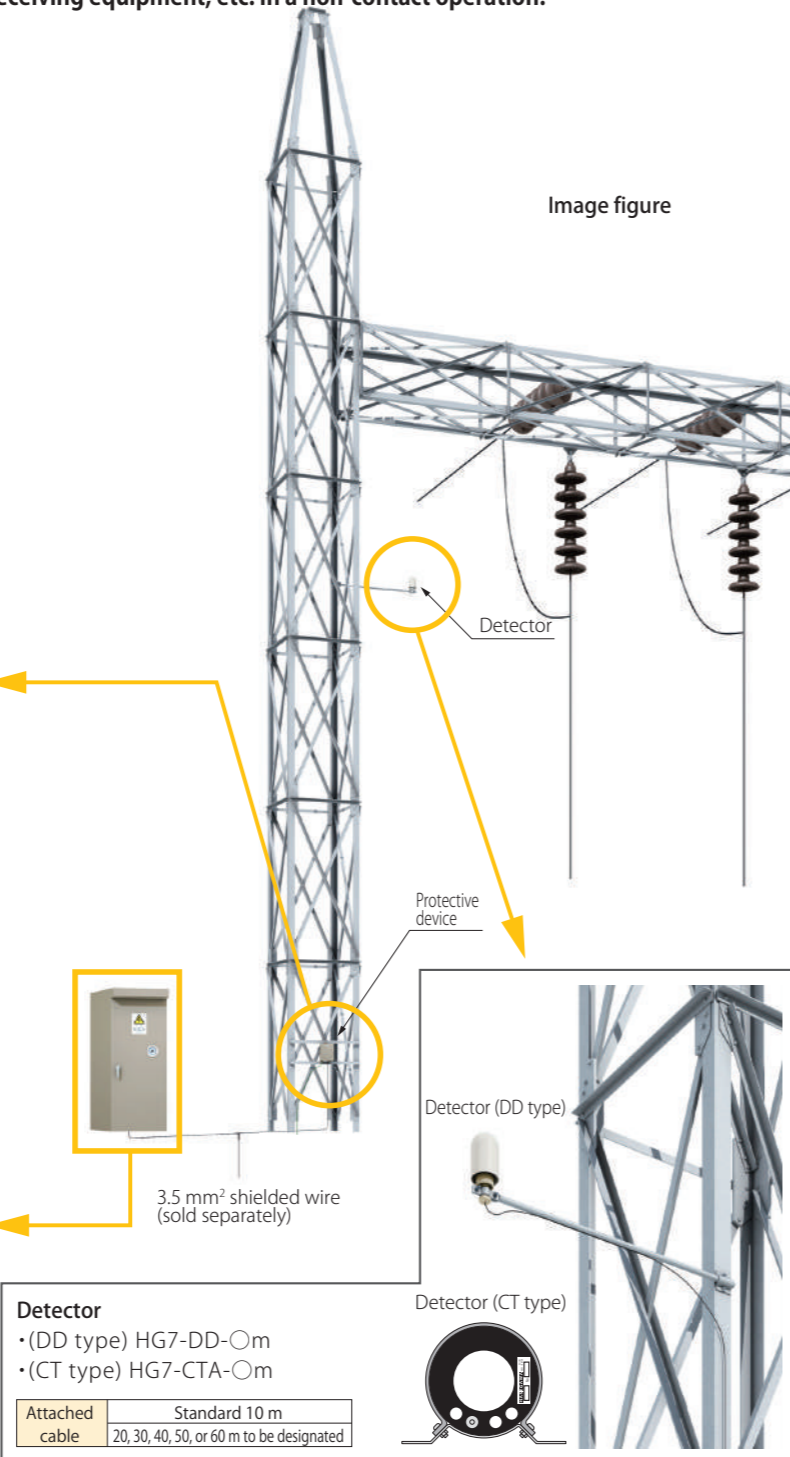

### Rating table

| Indicating type of the measuring instrument   | Voltage switching indication  |  | Indication proportional to voltage |
|---|---|--|------------------------------------|
| Type of Controller (*1)                       | Single-phase detection  | SM1AH(high sensitivity) SM1A(standard sensitivity) | DM1A                               |
|   | Two-phase detection   | SM2AH(high sensitivity) SM2A(standard sensitivity) | DM2A                               |
| Line voltage (50/60 Hz)                       | 3.3~550 kV  |  |                                    |
| Operating time at charging/power failure      | 0.5 sec or less (However, ratio of operating point setting: 70 % or less)             |  |                                    |
| Configuration                                 | 1c (for single phase), 1c × 2 (for two-phase)   |  |                                    |
| Switching capacity/100 VDC                    | Resistance load: 0.5 A, Induction load: 0.1 A   |  |                                    |
| Max. allowable circuit voltage                | 180V. DC, 140V. AC  |  |                                    |
| Output  | 0~1mA. DC   |  |                                    |
| Internal resistance                           | Less than 5 kΩ  | About 1.5kΩ  |                                    |
| Operation indication lamp                     | Charging: Red light, Power failure: Green light, No power: Extinguished (milky white) |  |                                    |
| Power supply voltage                          | Standard: 110 V. DC (Others: 24 V, 220 V)   |  |                                    |
| Power supply current                          | 75 mA (for single phase), 100 mA (for two-phase)                                      |  |                                    |
| Withstand voltage, insulation resistance (*2) | 2 kV, AC-1 min; 10 MΩ or more/500 V, DC   |  |                                    |
| Impulse withstand voltage                     | ±7 kV, 1.2 × 50 μS (between terminals in a lump ~ terminal E & case)                  |  |                                    |

\* 1. DM1A & DM2A in the table are of standard sensitivity. In addition to these, there is the low-sensitivity type SM (L).  
\* 2. Between terminals in a group and case. However, terminal E could be included in the terminal group or excluded during the test.

### How to decide the specification

| Installation site of detector | Outdoors            |          | Indoor              |          | Inside the cubicle |          |
|-------------------------------|---------------------|----------|---------------------|----------|--------------------|----------|
|                               | Control equipment   | Detector | Control equipment   | Detector | Control equipment  | Detector |
| Nominal line voltage          |                     |          |                     |          |                    |          |
| 3.3kV                         | —                   | —        | H                   | CT       | H                  | CT       |
| 6.6kV                         |                     |          | H, ST               | CT       | H, ST              | CT       |
| 11kV                          | H                   |          | H                   |          |                    |          |
| 22kV                          | H, ST               |          | H, ST               |          | H                  | DD       |
| 33kV                          | ST                  |          | ST                  |          | ST                 |          |
| 40~160kV                      |                     |          |                     |          |                    |          |
| 161kV~550kV                   | Low sensitivity (L) |          | Low sensitivity (L) |          | —                  | —        |

\* As for H, use high sensitivity (H) of the type SM.  
\* As for ST, use standard sensitivity of type SM or type DM.

# VOLTECT SPECIFICATION TABLE

## VOLTECT SPECIFICATION TABLE

Note: When your receipt of client order or when your offering quotation to the client, please write its q'ty and check  in for your confirmation.

Date:

|                                   |                                     |                                    |
|-----------------------------------|-------------------------------------|------------------------------------|
| Order: <input type="checkbox"/>   | Quotation: <input type="checkbox"/> | Delivery date:                     |
| Customer's name and address:      |                                     | Delivery place:                    |
| Tel/Fax:                          |                                     | Tel/Fax:                           |
| The person in charge(Name & Sec.) |                                     | Installation place name & address: |
| Tel/Fax:                          |                                     |                                    |

|                                 |                            |   |                                 |
|---------------------------------|----------------------------|---|---------------------------------|
| Normal line voltage<br>_____ kV | Detector insalltion place: | Outdoor <input type="checkbox"/>                      | Indoor <input type="checkbox"/> |
|                                 |                            | In board <input type="checkbox"/>                     |                                 |
|                                 |                            | Internal GIS sensor equipped <input type="checkbox"/> |                                 |

※Check instruction manual P.12 (Notice for Interval Distance Table), and please select the sensitivity of the controller.

|   |                        |
|---|------------------------|
| In case changing a installed Voltect, please write its controller's manufacturing number and so on for avoiding its mis-specification and for its confirmation: |                        |
| Installed controller type: HG7- M A   | Manufacturing No.      |
| Q'ty set  | Made by: date and year |

| Controller: | Type      | Controller Sensitivity | Q'ty | Operation power  | Color  | Special specification                       |
|-------------|-----------|------------------------|------|--|--|---|
| Single      | HG7-SM1A  | Standard               | set  | (Standard) 110V.DC (75~143V) <input type="checkbox"/><br>(Non standard) 24V.DC (21~32V) <input type="checkbox"/> | (Standard) 5Y7/1(Glossy) <input type="checkbox"/><br>(Non standard) 7.5BG6/1.5(Glossy) <input type="checkbox"/><br>N7(Glossy) <input type="checkbox"/> | English name plate <input type="checkbox"/> |
|             | HG7-SM1AH | High                   | set  |  |  |   |
|             | HG7-SM1AL | Low                    | set  |  |  |   |
|             | HG7-DM1A  | Standard               | set  | Below, built-in converter (*Please select the -S model for the Protector.)                                       |  |   |
| Two phase   | HG7-SM2A  | Standard               | set  | 110V.DC (90~170V) <input type="checkbox"/>   |  |   |
|             | HG7-SM2AH | High                   | set  |  |  |   |
|             | HG7-SM2AL | Low                    | set  | 220V.DC (110~250V) <input type="checkbox"/>  |  |   |
|             | HG7-DM2A  | Standard               | set  | 110V.AC (85V~132V) <input type="checkbox"/>  |  |   |

| Protector: | Type                           | Q'ty | Color   | Special specification                       |
|------------|--------------------------------|------|---|---|
| Single     | HG7-P1B (Standard)             | set  | (Standard) 5Y7/1(Glossy) <input type="checkbox"/><br>(Non standard) N7(Glossy) <input type="checkbox"/> | English name plate <input type="checkbox"/> |
|            | HG7-P1B-S (Built-in converter) | set  | 7.5BG6/1.5 (Semi Glossy) <input type="checkbox"/>   |   |
| Two phase  | HG7-P2B (Standard)             | set  |   |   |
|            | HG7-P2B-S (Built-in converter) | set  |   |   |

| Detector: | Type | Q'ty | Lengths of shield cable  | Color(Only for DD Type)  |
|-----------|------|------|--|--|
| HG7-DD-   | m    | set  | Please enter the model number in 10-meter increments in the model number field.<br>(Standard) 10m<br>Example :HG7-DD-10m | (Standard) N7(Glossy) <input type="checkbox"/><br>(Non standard) 5Y7/1 (Glossy) <input type="checkbox"/> |
|           | m    | set  |  |  |

| Wide range AC Voltmeter | Type    | Scale  | Q'ty | Cover color  |
|-------------------------|---------|--|------|--|
|                         | DVF-11M | It's different depending on the line voltage, so please refer to a wide angle meter specification (VHG07-S-001). | set  | (Standard) N1.5 <input type="checkbox"/><br>(Non standard) 7.5BG4/1.5 <input type="checkbox"/> |

| Shield Cable | Type   | Conductor's section area | Conductor's inner core | Length | Piece |
|--------------|--------|--------------------------|------------------------|--------|-------|
|              | CVV-SB | 3.5mm <sup>2</sup>       | 1c                     | m      | pc.   |

# Grounding Hook

---

- Grounding Hook ..... P.51
- Disconnecter Hook Stick ..... P.58
- Discharge Stick ..... P.59

# Type H

Universal Type for Cubicle

With Bag for housing

### ■Features

- The clip is L-shaped
- It's easily install and hard to detach.
- Soft and clear coated grounding wire.

### ■Dimensions

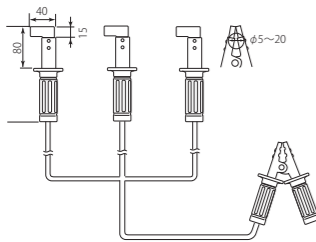

## Standard model for Cubicle and high voltage receiving equipment.



### ■Accessory



Bag for housing

### ■Specifications

| Type | Tip metal fitting | Grounding wire  | Grounding metal fitting | Hammer-in type grounding bar | Bag for housing              | Weight      |
|------|-------------------|---|-------------------------|------------------------------|------------------------------|-------------|
| H    | Clip              | 22mm <sup>2</sup> ×1.2m×3 wires<br>8mm <sup>2</sup> ×5 m×1 wire | Clip                    | None                         | Portable type<br>300×360×110 | About 3.5kg |

# Type HA-W

Universal Type for Cubicle

With Bag for housing

Check the QR code for details.



### ■Dimensions

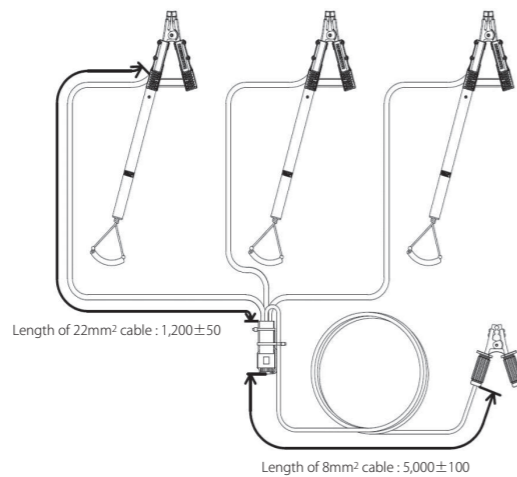
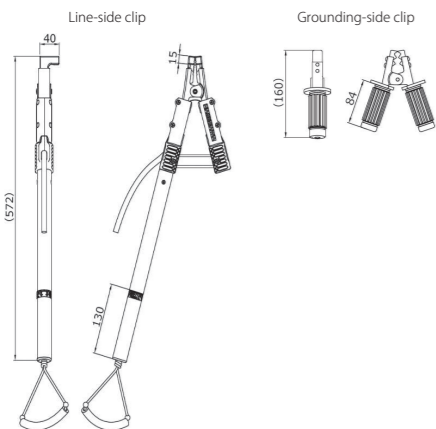

### ■Accessory



Bag for housing

### ■Specifications

| Type | Tip metal fitting | Overall length | Grounding wire  | Grounding metal fitting | Hammer-in type grounding bar | Bag for housing              | Weight      |
|------|-------------------|----------------|---|-------------------------|------------------------------|------------------------------|-------------|
| HA   | Clip              | 572mm          | 22mm <sup>2</sup> ×1.2m×3 wires<br>8mm <sup>2</sup> ×5 m×1 wire | Clip                    | None                         | Portable type<br>400×600×100 | About 4.5kg |

## Improved model from type H.



When you pull the rope, clip is opened.



When you push the rope, clip is closed.



# Type HC

Universal Type for Cubicle

With bag for housing

### ■Dimensions

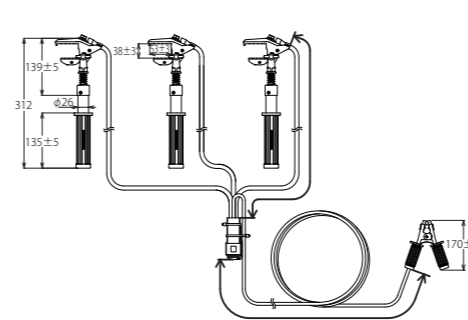

### ■Accessory



Bag for housing

# Type HF

Universal Type for Cubicle

With bag for housing

### ■Dimensions

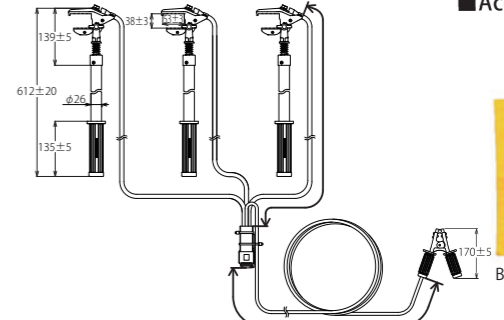

### ■Accessory



Bag for housing



Hammer-in type grounding bar

# Type S

For Round Bus Bar

With carrying case

### ■Dimensions

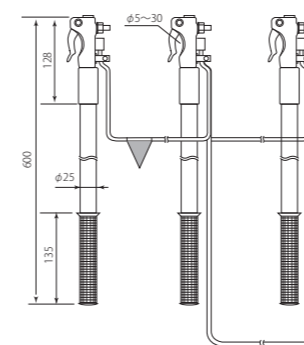

### ■Accessory

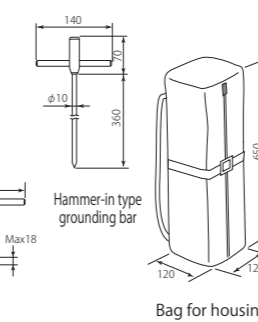

Bag for housing

### ■Specifications

| Type | Tip metal fitting         | Length of insulating stick              | Grounding wire   | Grounding metal fitting | Hammer-in type grounding bar | Bag for housing              | Weight      |
|------|---------------------------|---|--|-------------------------|------------------------------|------------------------------|-------------|
| HC   | Wide angle ajustable type | Epoxy pipe (φ26×38mm) with rubber grip  | 14mm <sup>2</sup> ×1m×3 wires<br>8mm <sup>2</sup> ×7m×1 wire                               | Clip                    | None                         | Portable type<br>300×360×110 | About 3.4kg |
| HF   | Wide angle ajustable type | Epoxy pipe (φ26×338mm) with rubber grip | 22mm <sup>2</sup> ×1.5m×3 wires<br>8mm <sup>2</sup> ×15m×1 wire                            | Clip                    | φ10 steel bar                | Portable type<br>400×600×100 | About 5.6kg |
| S    | MA122-A                   | Neo pipe (φ25×337mm) with rubber grip   | 22mm <sup>2</sup> ×1.5m×2 wires (with red triangular flag)<br>8mm <sup>2</sup> ×15m×1 wire | SA107-B                 | φ10 steel bar                | Portable type<br>650×120     | 5.0kg       |

Type S is made by Sunasaki Seisakusho.

# Grounding Hook

## A wide variety of lineup according to the application

### When ordering, please determine the followings.

1. Type of tip metal fitting
2. Type of insulating stick (supplementary connecting type, telescopic type)
3. Length and diameter of insulating stick
4. Cross-sectional area and length of earth wire
5. Type of grounding metal fitting
6. Working voltage

### Attention

- Three-phase/one set (three-unit set) is the standard (except for railways).
- The bag for housing is sold separately (except for partial products).
- The products are manufactured to order, so there may be cases when they are non-returnable.

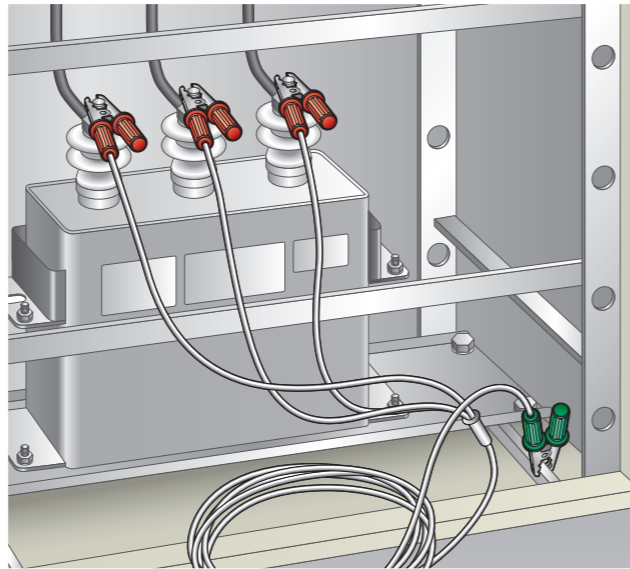

### How to connect operating rod (As a standard, a rod of 3 m or less consists of a single rod.)

Figures inside ( ) indicate outside diameter of the rod.

| Length of operating rod     | Earth wire of 38 mm <sup>2</sup> or less is used.          |                                |   |
|-----------------------------|--|--------------------------------|---|
|                             | In the case of using a strong type tip metal fitting       |                                | In the case of using earth wire of 60 mm <sup>2</sup> or more |
| 3.5m (connection of 2 rods) | 1.5m (31φ) + 2.0m (34φ)                                    | 1.5m (31φ) + 2.0m (34φ)        | 1.5m (31φ) + 2.0m (34φ)                                       |
| 4.0m (connection of 2 rods) | 2.0m (31φ) + 2.0m (34φ)                                    | 2.0m (31φ) + 2.0m (34φ)        | 2.0m (31φ) + 2.0m (34φ)                                       |
| 4.5m (connection of 2 rods) | 2.5m (31φ) + 2.0m (34φ)                                    | 2.5m (31φ) + 2.0m (34φ)        | 2.5m (34φ) + 2.0m (39φ)                                       |
| 5.0m (connection of 2 rods) | 2.5m (31φ) + 2.5m (34φ)                                    | 2.5m (31φ) + 2.5m (34φ)        | 2.5m (34φ) + 2.5m (39φ)                                       |
| 6.0m (connection of 2 rods) | 3.0m (34φ) + 3.0m (39φ)                                    | 3.0m (34φ) + 3.0m (39φ)        | 3.0m (34φ) + 3.0m (39φ)                                       |
| 6.0m (connection of 3 rods) | 2m (34φ) + 2m (39φ) + 2m (39φ)                             | 2m (34φ) + 2m (39φ) + 2m (39φ) | 2m (34φ) + 2m (39φ) + 2m (39φ)                                |
| Kind of joint               | uses an insulating joint, and others use a metallic joint. |                                |   |

### Type of grounding wire (transparent vinyl covered electric wire)

| Cross-sectional area      | 8mm <sup>2</sup> | 14mm <sup>2</sup> | 22mm <sup>2</sup> | 38mm <sup>2</sup> | 60mm <sup>2</sup> | 100mm <sup>2</sup> |
|---------------------------|------------------|-------------------|-------------------|-------------------|-------------------|--------------------|
| Wire configuration        | 7/22/0.26        | 7/38/0.26         | 7/71/40/0.12      | 19/38/0.26        | 19/60/0.26        | 37/51/0.26         |
| Weight                    | 105g/m           | 180g/m            | 265g/m            | 455g/m            | 680g/m            | 1120g/m            |
| Finished outside diameter | 6.6mm            | 8.4mm             | 10.1mm            | 12.9mm            | 15.2mm            | 19.0mm             |

### Grounding metal fitting

Grounding metal fitting (SA107-B,C,D)

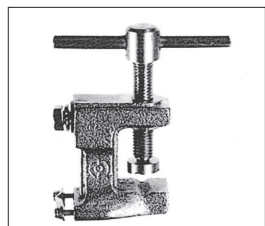

\* The photo shows SA107-C.

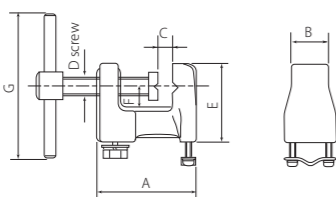

Valve type grounding handle (SA110)

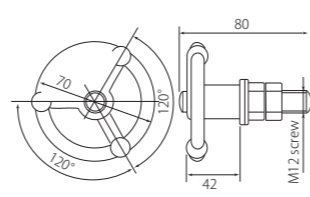

| Model   | Mounting method         | Applicable wire                       | A                           | B  | C  | D  | E  | F  | G  | Weight |      |
|---------|-------------------------|---------------------------------------|-----------------------------|----|----|----|----|----|----|--------|------|
| SA107-B | Screw tightening method | 8mm <sup>2</sup> ~ 14mm <sup>2</sup>  | 51                          | 18 | 18 | 10 | 39 | 13 | 65 | 280g   |      |
| SA107-C | Screw tightening method | 22mm <sup>2</sup> ~ 38mm <sup>2</sup> | 66                          | 24 | 27 | 12 | 53 | 14 | 95 | 570g   |      |
| SA107-D | Screw tightening method | 60mm <sup>2</sup> ~100mm <sup>2</sup> | 90                          | 30 | 38 | 12 | 75 | 23 | 95 | 1080g  |      |
| SA110   | Stud bolt type          | M12 stud                              | Valve type grounding handle |    |    |    |    |    |    |        | 320g |

# Grounding Hook Component

Table 1

When ordering the earth hook, please determine the following.

1. Type of tip metal fitting
2. Type of insulating stick (supplementary connecting type, telescopic type)
3. Length and diameter of insulating stick
4. Cross-sectional area and length of earth wire
5. Type of grounding metal fitting
6. Working voltage

### Attention

- Three-phase/one set is a standard. (Used with AC)
- The bag for housing is sold separately.
- The products are manufactured to order, so there may be cases when they are non-returnable. Please note this when placing an order.

### Fixed type tip metal fitting (The operating rod and tip metal fitting are fixed.)

| External appearance | Model name                        | Range of use (mm)   | Dimensions | Weight | Remarks                                 |
|---------------------|-----------------------------------|---|------------|--------|---|
|                     | MA121-A<br>Large size             | φ8 to 40  |            | 710g   | For round bus bar                       |
|                     | MA121-C<br>Slanted large size     | φ8 to 40  |            | 930g   | For round bus bar                       |
|                     | MA111-A<br>Universal type         | φ8 to 40<br>Thickness of bus bar within 12<br>Width within 75 |            | 930g   | For dual use of round and flat bus bars |
|                     | MA111-C<br>Slanted universal type | φ8 to 40<br>Thickness of bus bar within 12<br>Width within 75 |            | 1060g  | For dual use of round and flat bus bars |
|                     | MA122-A<br>Medium size            | φ5 to 25  |            | 370g   | For round bus bar                       |
|                     | MA115-A<br>Cubicle type           | φ5 to 25<br>Thickness of bus bar within 30<br>Width no limit  |            | 500g   | For dual use of round and flat bus bars |

# Grounding Hook Component

Table 2

● When ordering the earth hook, please determine the following.

1. Type of tip metal fitting
2. Type of insulating stick (supplementary connecting type, telescopic type)
3. Length and diameter of insulating stick
4. Cross-sectional area and length of earth wire
5. Type of grounding metal fitting
6. Working voltage

Attention

- Three-phase/one set is a standard. (Used with AC)
- The bag for housing is sold separately.
- The products are manufactured to order, so there may be cases when they are non-returnable. Please note this when placing an order.

## Detachable type tip metal fitting (The operating rod and tip metal fitting are detachable.)

| External appearance | Model name                                     | Range of use (mm)   | Dimensions | Weight | Remarks   |
|---------------------|--|---|------------|--------|---|
|                     | MA121-B<br>Large size                          | φ8 to 40  |            | 760g   | For round bus bar<br>Closed stocks (set items) of the type ZB, type YB have a groove width of 5.5 mm. |
|                     | MA121-D<br>Large slanted type                  | φ8 to 40  |            | 930g   | For round bus bar   |
|                     | MA111-B<br>Universal type                      | φ8 to 40<br>Thickness of bus bar within 12<br>Width within 75 |            | 980g   | For dual use of round and flat bus bars   |
|                     | MA111-D<br>Universal slanted type              | φ8 to 40<br>Thickness of bus bar within 12<br>Width within 75 |            | 930g   | For dual use of round and flat bus bars   |
|                     | MA105<br>Tip metal fitting for operating rod   |   |            | 170g   | To be used for all detachable models of the types MA115-B, ZB, and YB, except for closed stocks       |
|                     | MA105-S<br>Tip metal fitting for operating rod |   |            | 70g    | To be used for closed stocks of the types MA115-B, ZB, and YB   |

# Fixed Type

● When ordering the earth hook, please determine the following.

1. Type of tip metal fitting
2. Type of insulating stick (supplementary connecting type, telescopic type)
3. Length and diameter of insulating stick
4. Cross-sectional area and length of earth wire
5. Type of grounding metal fitting
6. Working voltage

Attention

- Three-phase/one set is a standard. (Used with AC)
- The bag for housing is sold separately.
- The products are manufactured to order, so there may be cases when they are non-returnable. Please note this when placing an order.

$$\text{(Closed stock)} = (\text{Operating rod with tip metal fitting} + \text{Grounding wire} + \text{Grounding metal fitting}) \times 3$$

(The bag for housing is sold separately.)

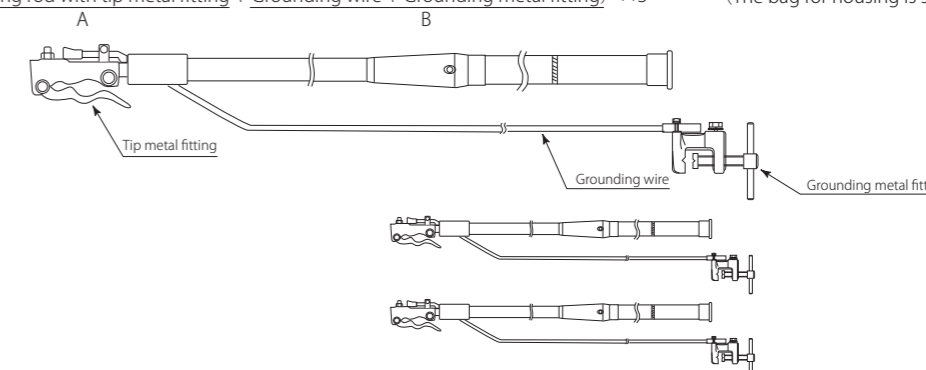

| A Model of tip metal fitting  | B Class | Breakdown of class            |                |                 | Grounding wire        | Grounding metal fitting | Applicable voltage |
|---|---------|-------------------------------|----------------|-----------------|-----------------------|-------------------------|--------------------|
|   |         | Length, kind of operating rod |                |                 |                       |                         |                    |
| Large fixed type<br>MA121-A<br>(MA121-C)                                | Type 5  | Neo pipe                      | 0.5m           | Single rod      | 22mm <sup>2</sup> ×3m | SA107C                  | 6.6kV              |
|   | Type 10 | "                             | 1.0m           | "               | "                     | "                       | "                  |
|   | Type 15 | "                             | 1.5m           | "               | 22mm <sup>2</sup> ×4m | "                       | 22kV               |
|   | Type 20 | "                             | 2.0m           | "               | "                     | "                       | "                  |
|   | Type 25 | "                             | 2.5m           | "               | 22mm <sup>2</sup> ×5m | "                       | 77kV               |
|   | Type 30 | "                             | 3.0m           | "               | "                     | "                       | "                  |
| Universal fixed type<br>MA111-A<br>(MA111-C)                            | Type 35 | "                             | 3.5m (1.5+2)   | Connecting type | 22mm <sup>2</sup> ×6m | "                       | "                  |
|   | Type 40 | "                             | 4.0m (2+2)     | "               | "                     | "                       | 154kV              |
|   | Type 45 | "                             | 4.5m (2.5+2)   | "               | 22mm <sup>2</sup> ×7m | "                       | "                  |
|   | Type 50 | "                             | 5.0m (2.5+2.5) | "               | "                     | "                       | "                  |
|   | Type 60 | "                             | 6.0m (3+3)     | "               | "                     | "                       | 275kV              |
|   | Type 60 | "                             | 6.0m (2×3)     | "               | "                     | "                       | "                  |
| Medium-sized fixed type<br>MA122-A<br>Fixed type for cubicle<br>MA115-A | Type 5  | "                             | 0.5m           | Single rod      | 14mm <sup>2</sup> ×3m | SA107B                  | 6.6kV              |
|   | Type 10 | "                             | 1.0m           | "               | "                     | "                       | "                  |
|   | Type 15 | "                             | 1.5m           | "               | 14mm <sup>2</sup> ×4m | "                       | 22kV               |
|   | Type 20 | "                             | 2.0m           | "               | "                     | "                       | "                  |

(Regarding the Type 60 described above, please determine either connection with two rods or three rods.)

# Detachable Type

$$\text{(Closed stock)} = (\text{Detachable tip metal fitting} + \text{Grounding wire} + \text{Grounding metal fitting}) \times 3 + (\text{Detachable operating rod}) \times 1$$

(The bag for housing is sold separately.)

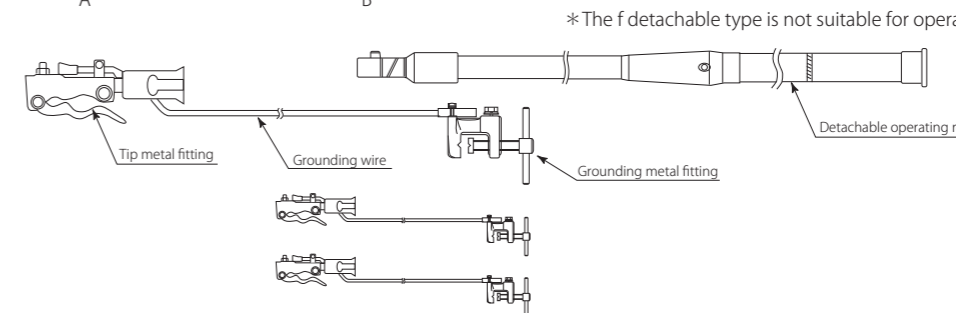

\* The f detachable type is not suitable for operation at 4 m or more.

| A Model of tip metal fitting                      | B Class | Breakdown of class            |              |                 | Grounding wire        | Grounding metal fitting | Applicable voltage |
|---|---------|-------------------------------|--------------|-----------------|-----------------------|-------------------------|--------------------|
|   |         | Length, kind of operating rod |              |                 |                       |                         |                    |
| Large detachable type<br>MA121-B<br>(MA121-D)     | Type 5  | Neo pipe                      | 0.5m         | Single rod      | 22mm <sup>2</sup> ×3m | SA107C                  | 6.6kV              |
|   | Type 10 | "                             | 1.0m         | "               | "                     | "                       | "                  |
|   | Type 15 | "                             | 1.5m         | "               | 22mm <sup>2</sup> ×4m | "                       | 22kV               |
|   | Type 20 | "                             | 2.0m         | "               | "                     | "                       | "                  |
|   | Type 25 | "                             | 2.5m         | "               | 22mm <sup>2</sup> ×5m | "                       | 77kV               |
|   | Type 30 | "                             | 3.0m         | "               | "                     | "                       | "                  |
| Universal detachable type<br>MA111-B<br>(MA111-D) | Type 35 | "                             | 3.5m (1.5+2) | Connecting type | 22mm <sup>2</sup> ×6m | "                       | "                  |
|   | Type 40 | "                             | 4.0m (2+2)   | "               | "                     | "                       | 154kV              |

Operating Rod of Compressed Tightening-Type Telescopic Model for Power Transmission Line

# Type Z

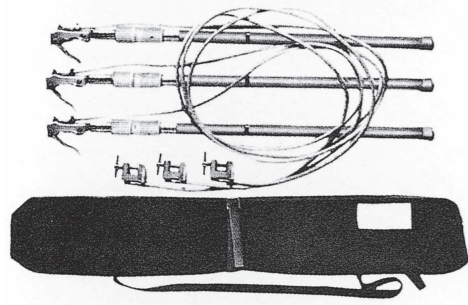

(Closed stock) = (Operating rod with tip metal fitting + Grounding wire + Grounding metal fitting) × 3 + (Bag for housing) × 1 or × 3

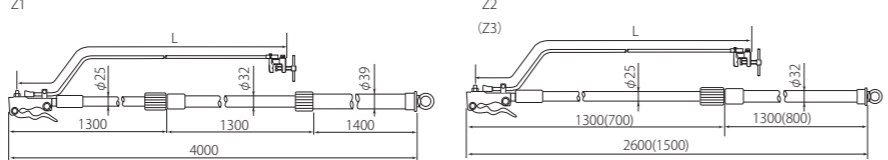

### ■ Grounding metal fitting SA107-C Insulating stick: Epoxy pipe

| Type | Applicable voltage | Tip metal fitting | Grounding wire        | Length at extended state | At storage | No. of connectors | Bag for housing             | Weight of contents & bag |
|------|--------------------|-------------------|-----------------------|--------------------------|------------|-------------------|-----------------------------|--------------------------|
| Z1   | 275kV              | MA121-A           | 22mm <sup>2</sup> ×5m | 4.0m                     | 1.8m       | 3                 | Capacity of 1-phase portion | 15.5kg                   |
| Z2   | 154kV              | "                 | 22mm <sup>2</sup> ×4m | 2.6m                     | 1.5m       | 2                 | Capacity of 3-phase portion | 11.0kg                   |
| Z3   | 77kV               | "                 | 22mm <sup>2</sup> ×3m | 1.5m                     | 1.1m       | 2                 | "                           | 8.8kg                    |

Operating Rod of Compressed Tightening-Type Telescopic Model for Power Transmission Line

# Type ZB



(Closed stock) = (Detachable tip metal fitting + Grounding wire + Grounding metal fitting) × 3 + (Operating rod) × 1 + (Bag for housing) × 1

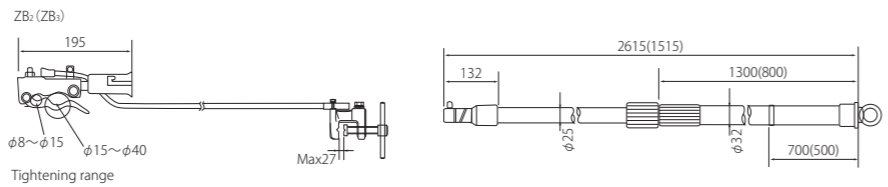

### ■ Grounding metal fitting SA107-C Insulating stick: Epoxy pipe

| Type | Applicable voltage | Tip metal fitting        | Grounding wire        | Length at extended state | At storage | No. of connectors | Bag for housing                            | Weight of contents & bag |
|------|--------------------|--------------------------|-----------------------|--------------------------|------------|-------------------|--|--------------------------|
| ZB2  | 154kV              | MA121-B (Groove: 5.5 mm) | 22mm <sup>2</sup> ×4m | 2.6m                     | 1.4m       | 2                 | Capacity of 3-phase portion for 1800 × 120 | 9.3kg                    |
| ZB3  | 77kV               | "                        | 22mm <sup>2</sup> ×3m | 1.5m                     | 0.9m       | 2                 | Capacity of 3-phase portion for 1200 × 120 | 7.8kg                    |

Operating Rod of Button Type Telescopic Model

# Type Y

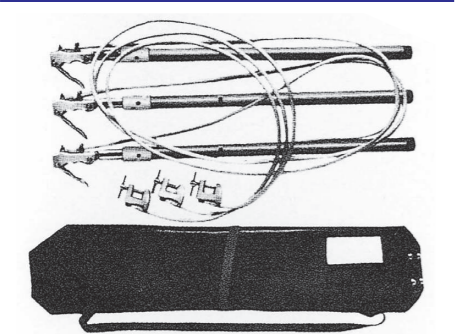

(Closed stock) = (Operating rod with tip metal fitting + Grounding wire + Grounding metal fitting) × 3 + (Bag for housing) × 1

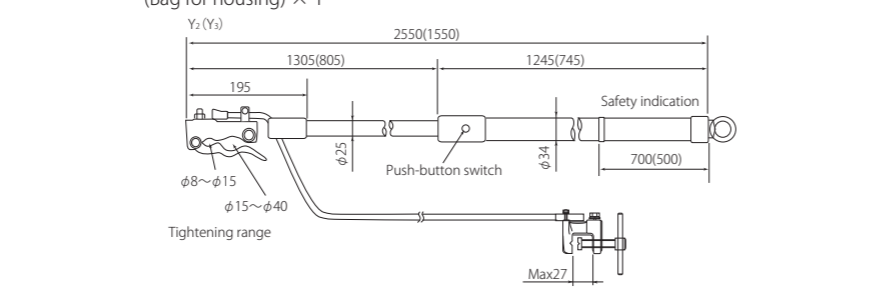

### ■ Grounding metal fitting SA107-C Insulating stick: Neo pipe

| Type | Applicable voltage | Tip metal fitting | Grounding wire        | Length at extended state | At storage | No. of connectors | Bag for housing             | Weight of contents & bag |
|------|--------------------|-------------------|-----------------------|--------------------------|------------|-------------------|-----------------------------|--------------------------|
| Y2   | 154kV              | MA121-A           | 22mm <sup>2</sup> ×4m | 2.5m                     | 1.4m       | 2                 | Capacity of 3-phase portion | 11.5kg                   |
| Y3   | 77kV               | "                 | 22mm <sup>2</sup> ×3m | 1.5m                     | 0.9m       | 2                 | "                           | 9.0kg                    |

Operating Rod of Button Type Telescopic Model

# Type YB

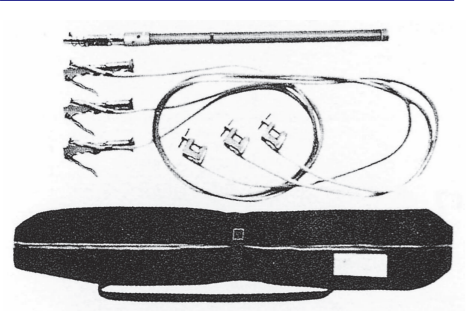

(Closed stock) = (Detachable tip metal fitting + Grounding wire + Grounding metal fitting) × 3 + (Operating rod) × 1 + (Bag for housing) × 1

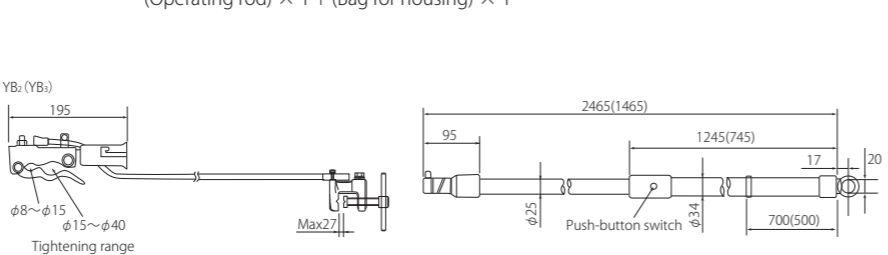

### ■ Grounding metal fitting SA107-C Insulating stick: Neo pipe

| Type | Applicable voltage | Tip metal fitting | Grounding wire        | Length at extended state | At storage | No. of connectors | Bag for housing             | Weight of contents & bag |
|------|--------------------|-------------------|-----------------------|--------------------------|------------|-------------------|-----------------------------|--------------------------|
| YB2  | 154kV              | MA121-B           | 22mm <sup>2</sup> ×4m | 2.4m                     | 1.4m       | 2                 | Capacity of 3-phase portion | 9.6kg                    |
| YB3  | 77kV               | "                 | 22mm <sup>2</sup> ×3m | 1.4m                     | 0.9m       | 2                 | "                           | 8.1kg                    |

# HSH-K6

Disconnecter Hook Stick with Voltage Detector

AC 6.6kV

Enhance Work Safety and Efficiency



### ■ Features

- Work safety and efficiency are improved by combining the voltage-detecting function to the medium voltage cutout operating rod.

### ■ Specifications

|  |  |
|--|--|
| Model  | HSH-K6   |
| Working voltage range                          | AC 6.6kV   |
| Operation starting voltage (Voltage to ground) | 1300V±20% (continuous indications of sound & light) (with insulated wire)  |
| Dielectric strength                            | Ditto: AC 50kV - 1 min   |
| Leakage current                                | 1 mA or less at dielectric strength test   |
| Indication of operation                        | Light Light emission: It shall be able to confirm luminance of 8,000 lux.<br>Sound Sound: 50 dB or more at a distance of 2 m |

|                             |                                       |
|-----------------------------|---------------------------------------|
| Operating temperature range | -10°C~+40°C                           |
| Structure                   | Waterproof (Water shall not ingress.) |
| Tensile performance         | 200kgf, 1 min                         |
| Battery                     | 6R61 or 6F22(9V) × 1 pcs              |
| Dimensions                  | About 470mm                           |
| Weight                      | About 390g                            |

\* Without the casing

# SA109 □-□

Hook Stick for D/S (Disconnecting Switch)

AC 10kV~110kV

### ■ Features

- There are lineups with or without the water drip shed (for outdoor use) as well as chain.

### ■ Specifications

| Model (SA109)                               | Applicable voltage |         |         |         |                             |                             |                             |                             |                             | Chain | Water drip shed |  |
|---|--------------------|---------|---------|---------|-----------------------------|-----------------------------|-----------------------------|-----------------------------|-----------------------------|-------|-----------------|--|
|   | Indoor             | A-1     | A-1.5   | A-2     | A-3                         | A2-4                        | A2-5                        | A2-6                        | A3-6                        |       |                 |  |
|   | Outdoors           | C-1     | C-1.5   | C-2     | C-3                         | C2-4                        | C2-5                        | C2-6                        | C3-6                        |       |                 |  |
| Applicable voltage                          | AC 10kV            | AC 20kV | AC 30kV | AC 40kV | AC 70kV                     |                             | AC 110kV                    |                             |                             |       |                 |  |
| Length of hook rod(L)                       | 1.0m               | 1.5m    | 2.0m    | 3.0m    | 4.0m (connection of 2 rods) | 5.0m (connection of 2 rods) | 6.0m (connection of 2 rods) | 6.0m (connection of 2 rods) | 6.0m (connection of 2 rods) |       |                 |  |
| Rod dia. & connecting method                | φ 31               | 1.0m    | 1.5m    | 2.0m    | 3.0m                        | 2.0m                        | 2.5m                        | —                           | —                           |       |                 |  |
|   | φ 34               | —       | —       | —       | —                           | 2.0m                        | 2.5m                        | 3.0m                        | 2.0m                        |       |                 |  |
|   | φ 39               | —       | —       | —       | —                           | —                           | —                           | 3.0m                        | 2.0m+2.0m                   |       |                 |  |
| Length of grip (ℓ o)                        | 0.3m               | 0.5m    | 0.5m    | 0.7m    | 0.7m                        | 1.0m                        | 1.0m                        | 1.0m                        | 1.0m                        |       |                 |  |
| Tip metal fitting for Disconnecter hook rod |                    | SA108-B |         |         | SA108-C                     |                             |                             | SA108-E                     |                             |       |                 |  |

# D □

Hook Stick for D/S in Cubicle

AC 6.6kV~30kV

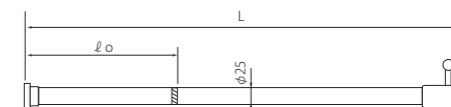

### ■ Specifications

| Class                | D1    | D2   | D3   | D4   |
|----------------------|-------|------|------|------|
| Length (L)           | 0.5m  | 1.0m | 1.5m | 2.0m |
| Length of grip (ℓ o) | 0.3m  | 0.3m | 0.5m | 0.5m |
| Applicable voltage   | 6.6kV | 10kV | 20kV | 30kV |

## HRD-27S Residual Electric Charge Discharging Stick

- Voltage detection functions
- Built-in resistance

**DC 27kV** (Maximum discharge voltage)



### ■ Features

- Allows for residual electric charge to be discharged safely and easily
- When discharging, allows for visual and auditory confirmation of discharge status through an audio and light emitting display at the center of the detector
- The metal fitting can be switched according to application (2 types)

This device is not a voltage detector. Use a voltage detector on the circuit to confirm that the power is not running before using this device.

### ■ Detector



### ■ Accessory



### ■ Dimensions

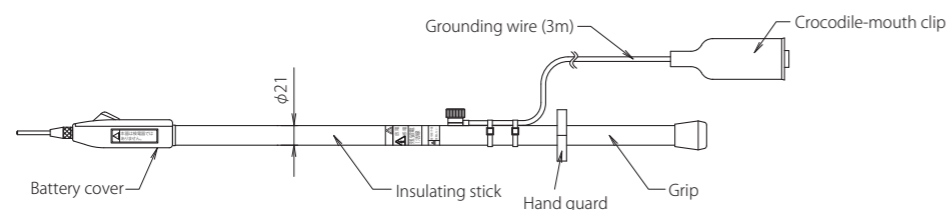
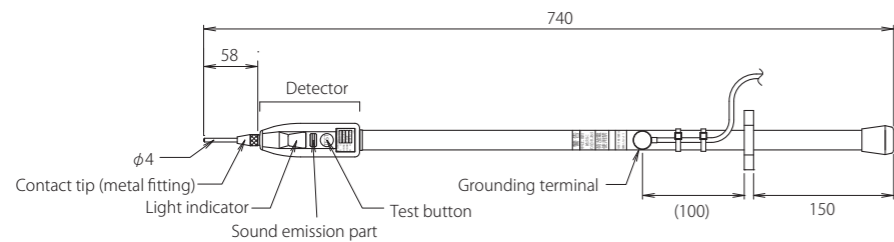

### ■ Specifications

|                             |   |
|-----------------------------|---|
| Discharge voltage           | DC27kV (Max)  |
| Discharge capacity          | 1 μF (Max)  |
| Discharge time              | 5 seconds or less (DC27 kV, 50 V or less at 1 μF)   |
| Discharge resistance        | 600kΩ   |
| Operation stop voltage      | DC40V ±20%  |
| Indication (Light/sound)    | Light: It shall be able to confirm in the luminance of 8,000 lux. Sound: 50 dB or more at a distance of 2 m |
| Battery                     | LR44 alkaline button cell (1.5 V) x2 pcs.   |
| Battery life                | Approx. 4 hours of continuous operation   |
| Operating temperature range | -10°C ~ +40°C   |
| Weight                      | About 800 g   |
| Accessories                 | Bag for housing , contact tip (hook metal fitting), each 1 pc.  |

## Uses sound and light to visualize the complete discharge of accumulated charge



## HRD-27 Residual Electric Charge Discharging Stick

- Built-in resistance

**DC 27kV** (Maximum discharge voltage)

### ■ Features

- Allows for residual electric charge to be discharged safely and easily
- The metal fitting can be switched according to application (2 types)

### ■ Dimensions

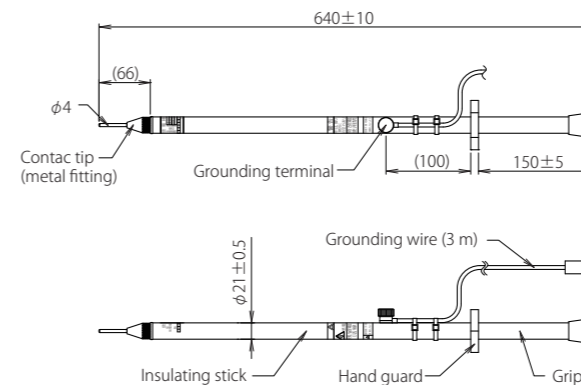

### ■ Specifications

|                             |   |
|-----------------------------|---|
| Discharge voltage           | DC27kV (Max)  |
| Discharge capacity          | 1 μF (Max)  |
| Discharge time              | 5 seconds or less (DC27 kV, 50 V or less at 1 μF)               |
| Discharge resistance        | 600kΩ   |
| Operating temperature range | -10°C ~ +40°C   |
| Weight                      | About 660 g   |
| Accessory                   | Bag for housing , contact tip (hook metal fitting) , each 1 pc. |

### ■ Accessory



## Order-made Residual Electric Charge Discharging Stick

- No built-in resistance

\*Select from the following specifications

- This product is custom built according to the following selected specifications ((1) to (4))

|  |   |
|--|---|
| (1) Length of insulation stick             | <input type="checkbox"/> 0.5m <input type="checkbox"/> 1.0m <input type="checkbox"/> 1.5m <input type="checkbox"/> 2.0m   |
| (2) Cross-sectional area of grounding wire | <input type="checkbox"/> 8mm <sup>2</sup> <input type="checkbox"/> 14mm <sup>2</sup>  |
| (3) Length of grounding wire               | <input type="checkbox"/> 2m <input type="checkbox"/> 3m <input type="checkbox"/> 4m <input type="checkbox"/> 5m <input type="checkbox"/> 6m<br><input type="checkbox"/> 7m <input type="checkbox"/> 8m <input type="checkbox"/> 9m <input type="checkbox"/> 10m |
| (4) Grounding metal fitting type           | *For the Dimensions, refer to P53.<br><input type="checkbox"/> Crocodile-mouth clip<br><input type="checkbox"/> Vise type (SA107-B)   |

## Simple Discharge stick with no built-in Internal Resistance

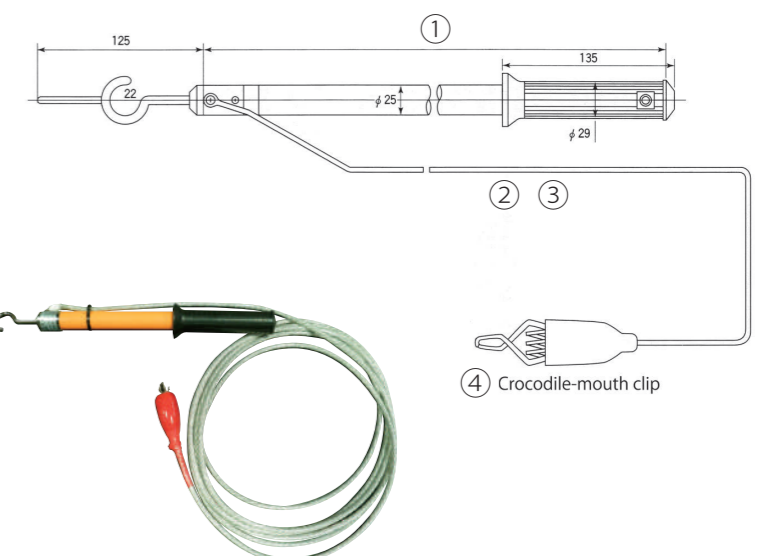

Index etc.  
Voltage Detector  
Phase Tester  
Voltage Detector Checker  
Device for Voltage Detection & Hot Line Proximity Alarm  
Railway Products  
Measuring Instrument  
Grounding Hook  
Disconnector Hook Stick  
Discharge Stick  
Information Materials

Index etc.  
Voltage Detector  
Phase Tester  
Voltage Detector Checker  
Device for Voltage Detection & Hot Line Proximity Alarm  
Railway Products  
Measuring Instrument  
Grounding Hook  
Disconnector Hook Stick  
Discharge Stick  
Information Materials

# Technical Data



---

■ Information Materials ..... P.63

# In order to use the voltage detector correctly

\*Unauthorized copying and reproduction is prohibited

## Low Voltage Use (For AC)

The contact area with the hand affects the sensitivity of the voltage detector. So, appropriate sensitivity cannot be obtained unless it is held firmly. Also, it is not possible to use rubber gloves for high voltages or gloves made from thick fabric.

### ■ Holding the voltage detector correctly

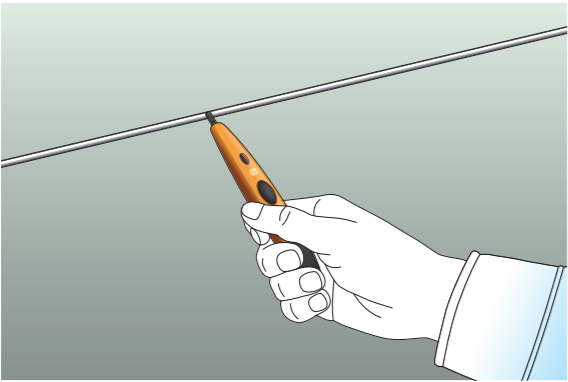
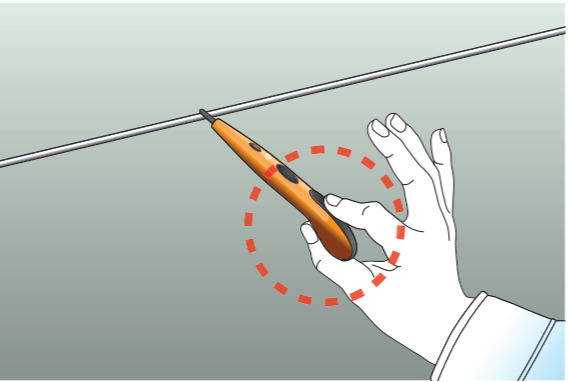
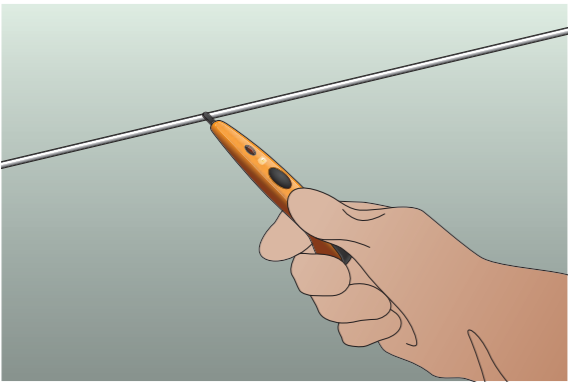
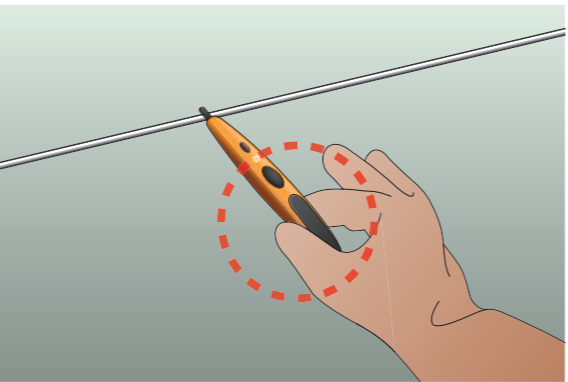
| ○ Good   | ✗ Bad  |
|--|--|
|   |                      |
|  |                     |
| ● Hold the grip firmly.  | ● It is not possible to detect the voltage correctly if the grip is held with the tips of the fingers. |

### ■ Visual inspection

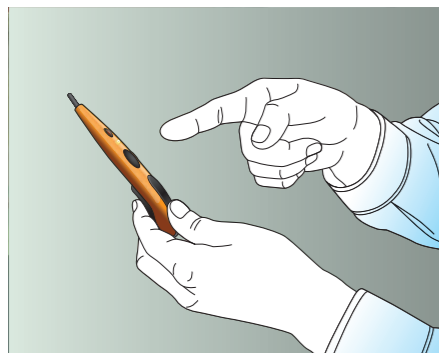

#### Visual inspection items

- Press the test button for about five seconds and check that there is no change in the lamp or the sound.
- Check that there are no problems such as damage, dirt, scratches or cracks.

### ■ Withstand voltage testing

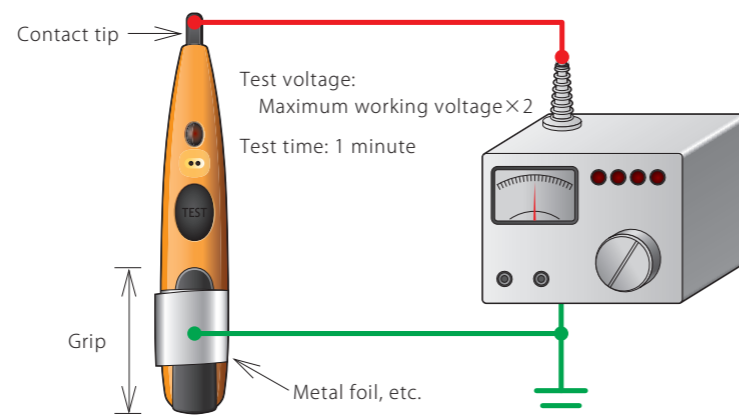



- Apply a voltage between the contact tip and the grip (at a position near the contact tip).

## Medium and Low Voltage Use (For AC)

The contact area with the hand affects the sensitivity of the voltage detector. So, appropriate sensitivity cannot be obtained unless it is held firmly.

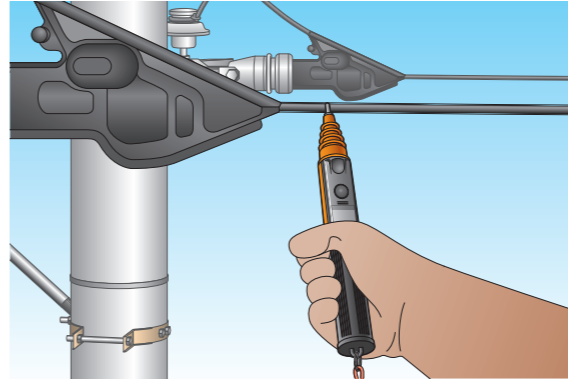
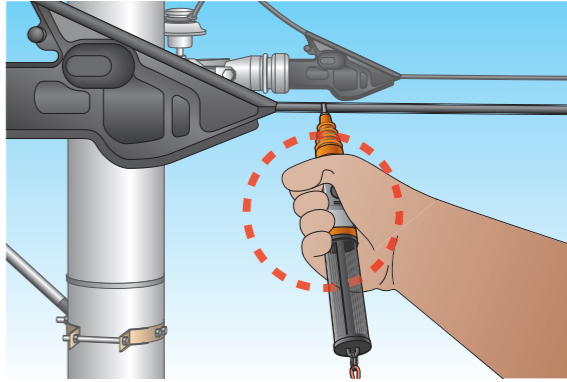
### ■ Holding the voltage detector correctly

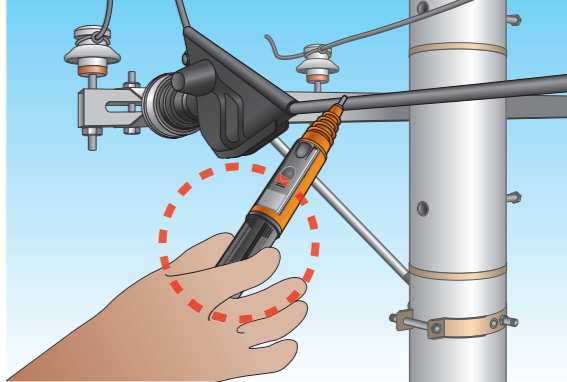
| ○ Good   | ✗ Bad   |
|--|---|
|   |    |
|  |   |
| ● Hold the grip firmly.  | ● Never hold a part other than the grip when detecting voltages. This is extremely dangerous.<br>● It is not possible to detect the voltage correctly if the grip is held with the tips of the fingers. |

### ■ Visual inspection

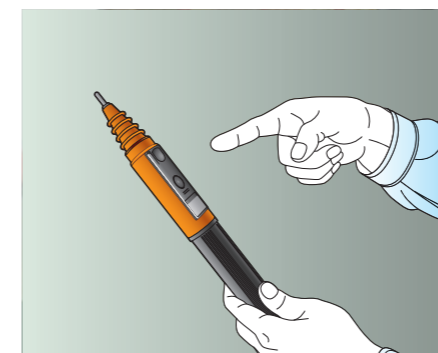

#### Visual inspection items

- Press the test button for about five seconds and check that there is no change in the lamp or the sound.
- Check that there are no problems such as damage, dirt, scratches or cracks.

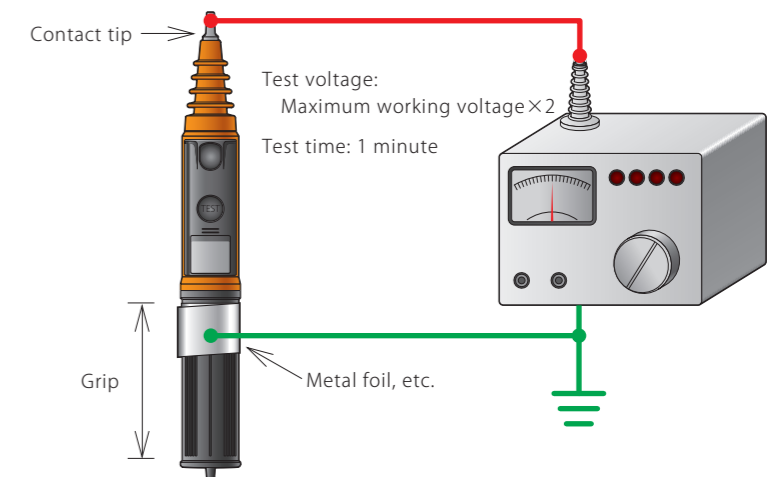

### ■ Withstand voltage testing



- Apply a voltage between the contact tip and the grip (at a position near the contact tip).

# Medium Voltage & High Voltage Detector Use

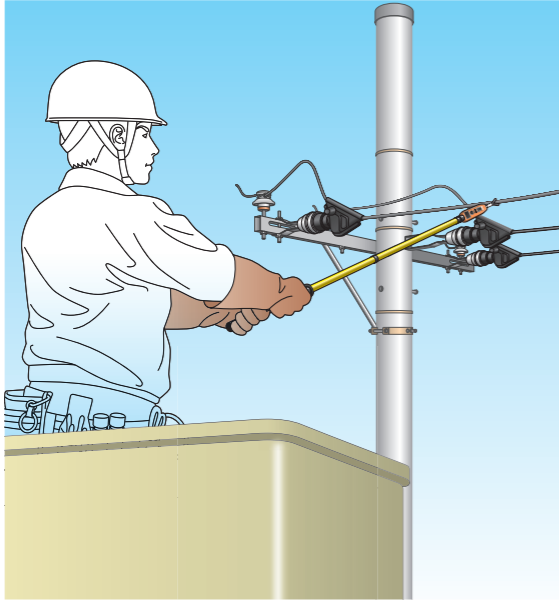
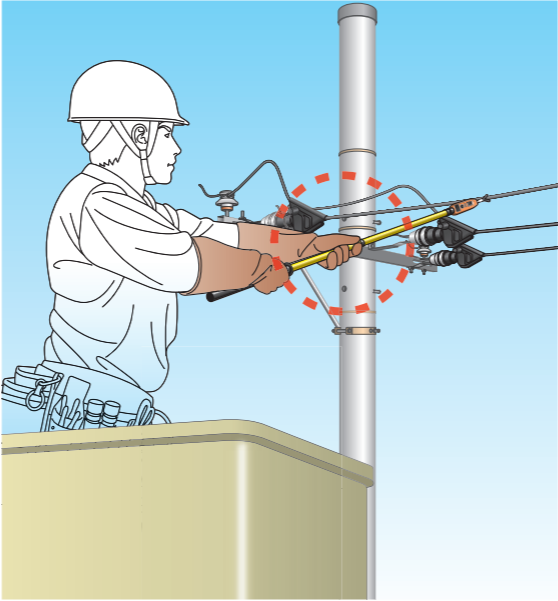
## ■ Holding the voltage detector correctly

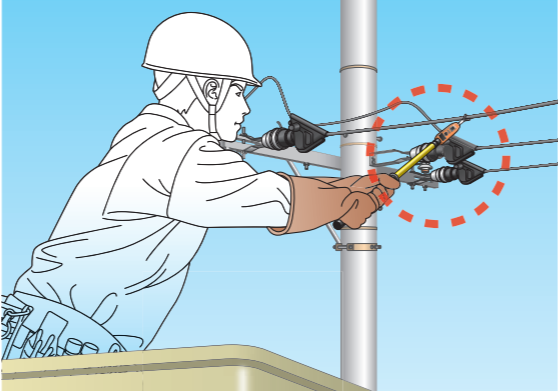
| ○ Good  | ✗ Bad  |
|---|--|
|   |   |
| <p>■ During storage</p>    |  |
| <p>■ During use</p>  <p>Extend as far as possible</p>                              |    |
| <ul style="list-style-type: none"> <li>● Hold the grip firmly.</li> <li>● Telescopic type voltage detectors should be extended as far as possible for use.</li> </ul> | <ul style="list-style-type: none"> <li>● Never hold a part other than the grip when detecting voltages.</li> <li>● Do not use a telescopic type voltage detector to detect voltages in its shortened state.</li> </ul> |

## ■ Visual inspection

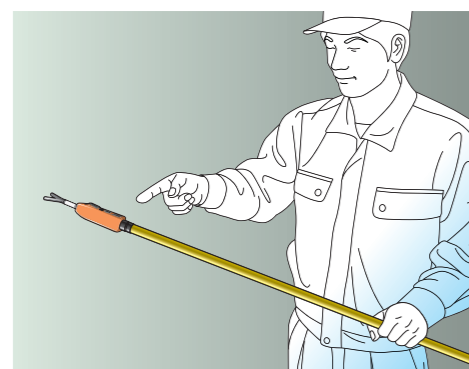

### Visual inspection items

- Press the test button for about five seconds and check that there is no change in the lamp or the sound.
- Check that there are no problems such as damage, dirt, scratches or cracks.

## ■ Withstand voltage testing

### ■ When test voltage is applied in batches

Test voltage is applied between the detector and the grip

Example:HST-30

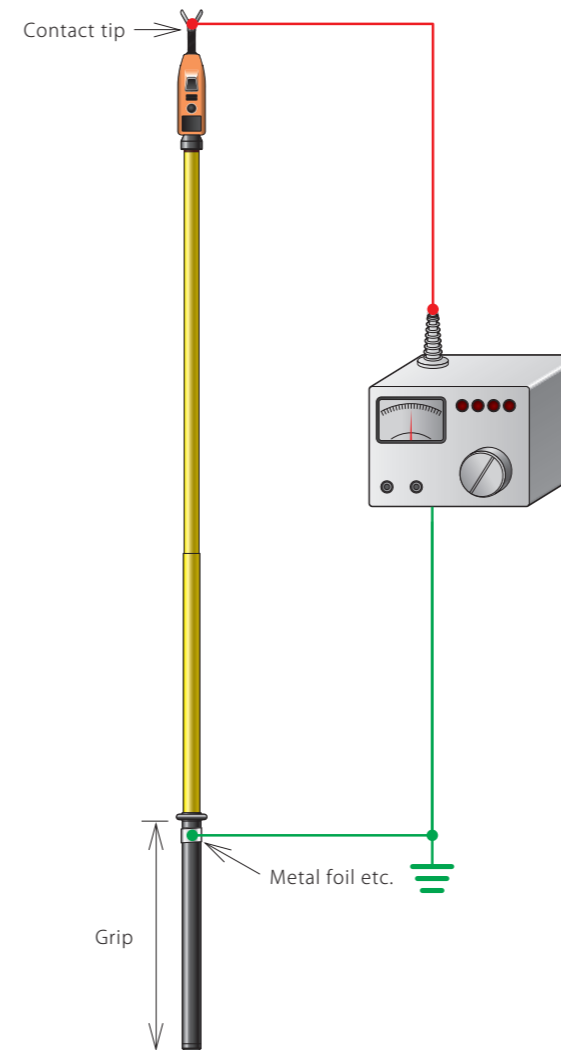

Test voltage: Maximum working voltage × 2  
Test time: 1 minute

Working voltage range: 3kV ~ 34.5kV  
34.5kV (Maximum working voltage) × 2 = 69kV (Test voltage)

\*We apply a test voltage of 70 kV

Hasegawa Electric has defined the withstand voltage testing methods by quoting the regulations and others listed below.

- March 28, 1961 LSB Notification No. 247  
"Regulations on the performance of personal insulating protective equipment"  
(Ministry of Health, Labour and Welfare)
- 4th Edition Test standards for personal insulating protective equipment, etc.  
(Issued by: The Expert Group of Expertise on Industrial Safety)
- JIS C 4510-1991 Hook bars for disconnecting switch operation

### ■ When test voltage is applied in installments

The test area is divided into 30 cm lengths and test voltage is applied to each section

Example:HST-70

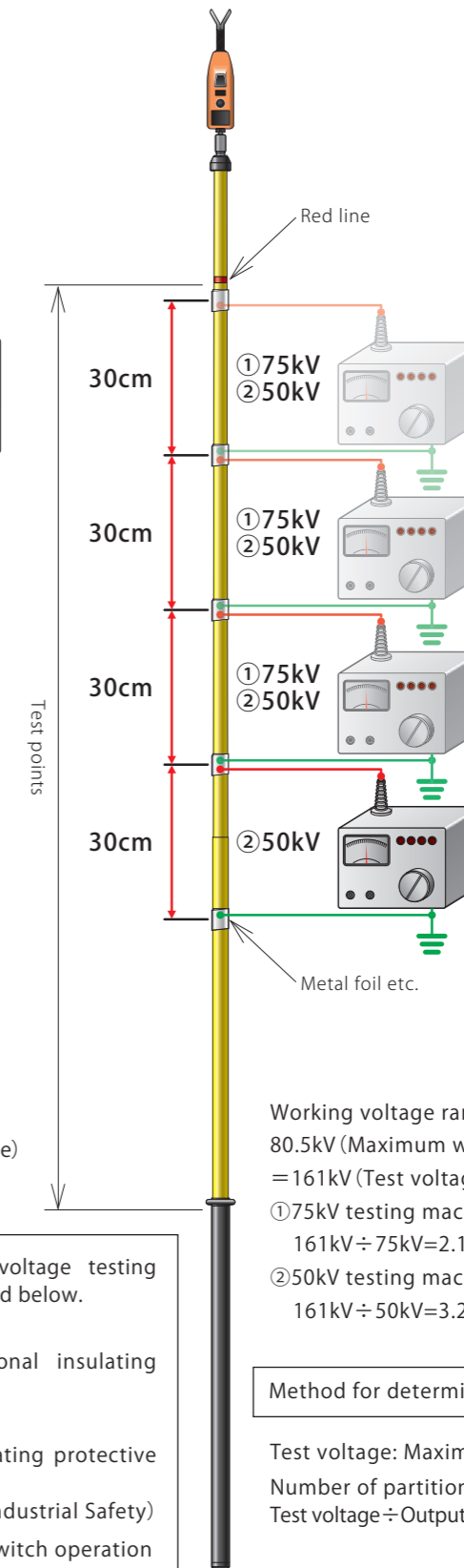

Working voltage range: 20kV ~ 80.5kV  
80.5kV (Maximum working voltage) × 2 = 161kV (Test voltage)

- ① 75kV testing machine  
 $161kV \div 75kV = 2.15 = \text{trisection (Round up)}$
- ② 50kV testing machine  
 $161kV \div 50kV = 3.22 = \text{quartering (Round up)}$

Method for determining the number of sections

Test voltage: Maximum working voltage × 2  
Number of partitions:  
Test voltage ÷ Output voltage of the test instrument

\*The "Split-application test" cannot be performed for voltage detectors(HST-20N, HSR-90N) with resistance in the insulating rod.

# Confirming Dead-line Work



① Visual inspection of appearance and structure  
Battery check by pushing the test button

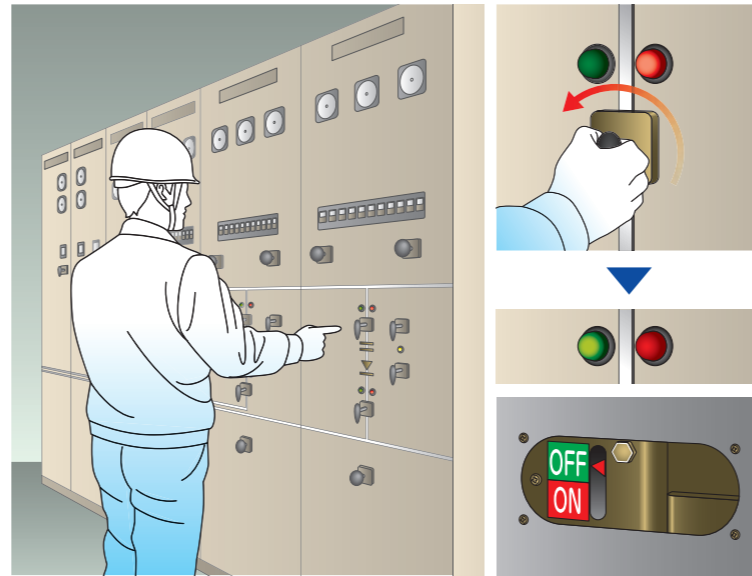

③ Turn off the Circuit Breaker  
Turn off the disconnector switch

④ Bring the voltage detector into contact with Line 1, confirm the power is off.  
Bring the voltage detector into contact with Line 2, confirm the power is off.  
Bring the voltage detector into contact with Line 3, confirm the power is off.  
\* Confirm all 3 lines

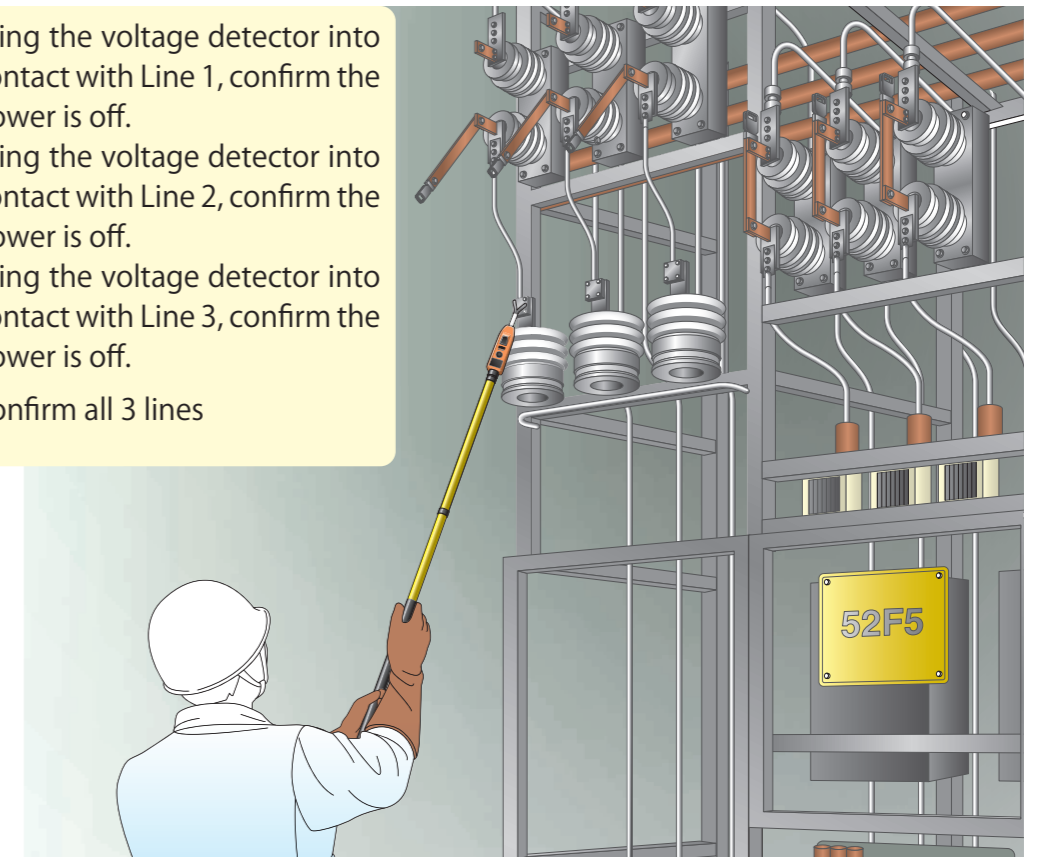

⑤ Visual check of grounding hook set.  
Appearance and construction check

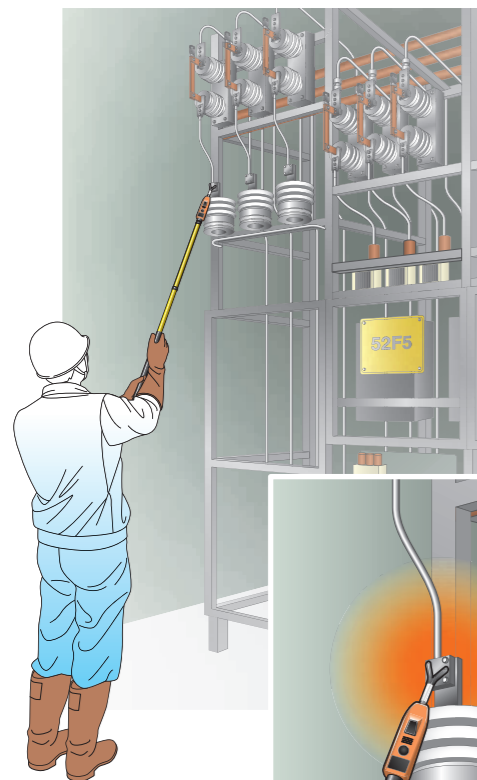

② Confirm normal operation of voltage detector contacting any charged conductor already known

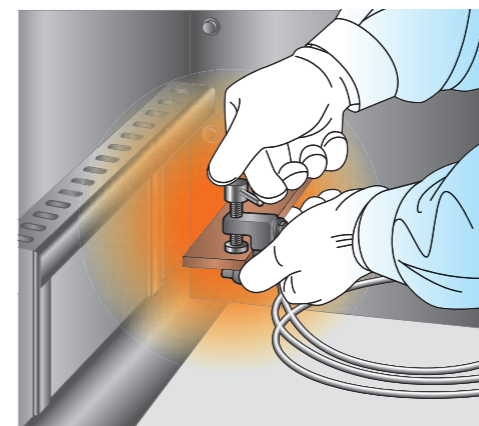
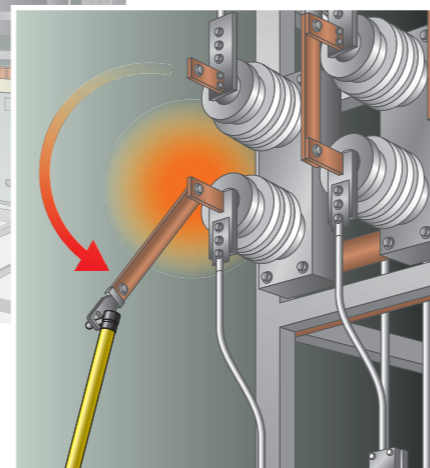
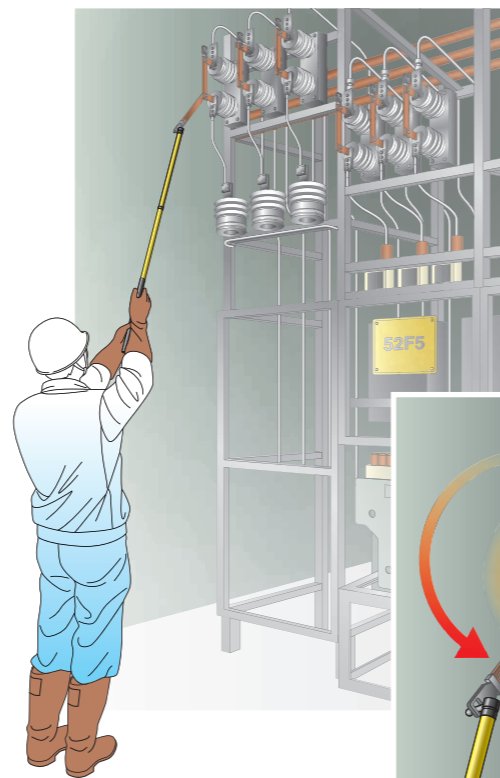

⑥ Connect the grounding device to earth terminal

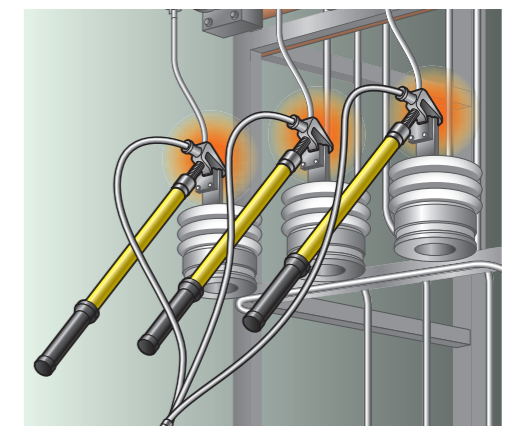

⑦ Connect the contact clamp to Line 1  
Connect the contact clamp to Line 2  
Connect the contact clamp to Line 3  
\* Connect all 3 lines

Index etc.  
Voltage Detector  
Phase Tester  
Voltage Detector Checker  
Device for Voltage Detection & Hot Line Proximity Alarm  
Railway Products  
Measuring Instrument  
Grounding Hook  
Disconnector Hook Stick  
Discharge Stick  
Information Materials

Index etc.  
Voltage Detector  
Phase Tester  
Voltage Detector Checker  
Device for Voltage Detection & Hot Line Proximity Alarm  
Railway Products  
Measuring Instrument  
Grounding Hook  
Disconnector Hook Stick  
Discharge Stick  
Information Materials

## ■ Warranty period

- Product warranty period is one year after purchase. If any failure, trouble, etc. is caused during normal use in the course of the warranty period, we will repair or replace it free of charge.

## ■ Scope of warranty

- If disassembly, modification, etc. is performed by customers, the product becomes outside the scope of warranty.
- Consumable parts such as batteries attached to products, etc. are outside the scope of warranty. Furthermore, because attached batteries are provided for the purpose of confirming operation, early replacement is recommended.

## ■ Repair

- If the product malfunctions, please inquire at a sales office of our company or a sales agent. Requests for repair will be received through sales agents.
- When an estimate before repair is needed, please request it when asking for the repair. When declining repair after submission of the "estimate before repair," the cost of diagnosis will be requested.
- Warranty period after repair is six months. Scope of warranty is limited to the corresponding portion(s) repaired, and even within that warranty period, any new problem arising is outside the scope of warranty.

### [Period for repair]

Materials and components for repair are kept for a minimum of five years after stopping manufacture of a product. However, please note that there are cases in which repair can become impossible before that period has expired.

## ■ Recommended period for replacement

### (voltage detector, phase tester, auxiliary device for voltage detection, etc.)

Products can be used for a long period if they are handled with sufficient care. However, it is inevitable that functional deterioration occurs to the strength of components, insulation performance, etc. due to aging, micro-cracks caused by shocks when handling resin parts, etc. For safety, please use the product until the recommended time for replacement under product control. The table to the right summarizes recommended replacement periods.

For a detailed table, please inquire at our company's homepage (URL is given on the back cover of the catalog) or a sales office.

| Product classification   | Recommended period for replacement |
|--|------------------------------------|
| Low voltage detector   | 3 to 5 years                       |
| High voltage detector  | 5 to 7 years                       |
| High voltage & special high voltage detector                       |                                    |
| High voltage & special high voltage detector (Non-extendable type) | 5 to 10 years                      |

## ■ Periodic inspection, calibration test

- For high voltage and special high voltage detectors, we recommend periodic inspection at least once a year. For requests, please inquire at a sales office of our company, or a sales agent.
- After the calibration test, we will issue a test report, calibration certificate, and traceability certificate.
- If calibration documents are required when purchasing a new product, please request them when placing an order.

## ■ Consigned testing

Taking advantage of being a leading maker of domestic test equipment and many years of experience, we will execute withstand voltage tests for products even made by other companies.



Voltage detector test equipment



Simulated power pole for electricity distribution line

## ■ ISO management system Acquiring certification of ISO9001, ISO14001

Hasegawa Electric Co., Ltd. has acquired certification of "ISO9001," which is the international standard of the Quality management system, and certification of "ISO14001," which is the international standard of the Environment management system.

ISO9001 Registration No.: 0921

ISO14001 Registration No.: E635

